

Panasonic

Operating Instructions

Color Laser Printer

Model No. **KX-P8410**

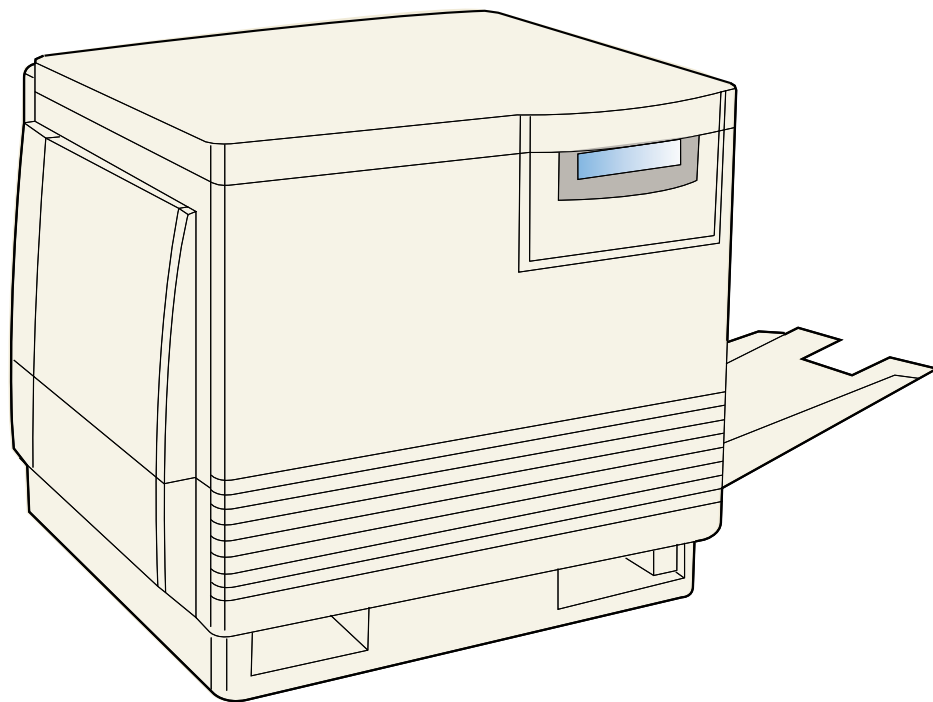

Please carefully read the Operating Instructions before operating. Keep this CD-ROM in the protective case. Do not expose the CD-ROM to direct sunlight or extreme heat and do not scratch or smudge the surface of the CD-ROM.

- Microsoft, Windows and Windows NT are registered trademarks of Microsoft Corporation in the United States and/or other countries.
- Pentium is a registered trademark of Intel Corporation.
- Adaptec and EZ-SCSI are trademarks of Adaptec, Inc.
- Centronics is a trademark of Centronics Data Computer Corporation.
- Adobe and Acrobat are trademarks of Adobe Systems Incorporated.
- Avery is a registered trademark and all Avery codes are trademarks of Avery Dennison Corporation.
- All other acknowledgements are trademarks or registered trademarks of their respective holders.

It is granted from Microsoft Corporation to use Microsoft® Windows® Screen Shots.
Acrobat® Reader copyright © 1987-1996 Adobe Systems Incorporated. All rights reserved.

Thank you for purchasing the Panasonic KX-P8410 Color Laser Printer.

The serial number is located on the label on the rear of the unit. For your convenience, record the number below and keep this book along with your proof of purchase, in the event of a theft or for future reference.

MODEL NO. **KX-P8410** SERIAL NO. _____
NAME OF RESELLER _____ DATE OF PURCHASE _____



As an Energy Star Partner, Panasonic has determined that this product meets the Energy Star guidelines for energy efficiency.
(The international Energy StarSM Logo is valid in U.S.A., Europe and Japan only.)

The operating instructions are subject to change without notice.

© KYUSHU MATSUSHITA ELECTRIC CO., LTD. 1997

End-User License Agreement

THIS IS A LEGAL AGREEMENT BETWEEN YOU AND PANASONIC. CAREFULLY READ ALL THE TERMS AND CONDITIONS OF THIS AGREEMENT PRIOR TO OPENING THE PACKET OF SOFTWARE PROGRAM. OPENING THE PACKET INDICATES YOUR ACCEPTANCE OF THESE TERMS AND CONDITIONS. If you do not agree to these terms and conditions, return the unopened packet and the other components of the Panasonic product to the place of purchase and your money will be refunded. No refunds will be given for the products that have an opened packet or missing components.

1. COPYRIGHT:

Panasonic has the right to license or has been granted to license the enclosed Software Program ("SOFTWARE"), developed and copyrighted by Kyushu Matsushita Electric Co., Ltd. or its licensor ("Licensor"). You acknowledge that you are receiving only a LIMITED LICENSE TO USE the SOFTWARE and related documentation, and that you shall obtain no title, ownership nor any other rights in or to the SOFTWARE and related documentation, all of which title and rights shall remain with Licensor and Panasonic.

2. LICENSE:

(1) You have the non-exclusive rights to use the SOFTWARE on your computer. (2) If you wish to use the SOFTWARE in your network, you may install the SOFTWARE into a network server and/or its clients and use the copies of SOFTWARE in your network. (3) You may make a reasonable quantities of copies of the SOFTWARE solely for backup or archival purposes. (4) You may not rent or lease the SOFTWARE, but you may transfer your right under this License Agreement on a permanent basis, provided that you transfer this Agreement, all copies of the SOFTWARE, all related documentation and your Panasonic product, and the recipient thereof agrees to the terms of this Agreement. (5) You may not reverse engineer, decompile or disassemble the SOFTWARE, except that in European Union and European Free Trade Association, you may have the limited right to reverse engineer, decompile or disassemble the SOFTWARE solely to the extent specifically permitted by the terms and conditions of Article 6 of the European Community's Directive for the Legal Protection of Computer Programs, OJL 122/42 (17 May 1991). (6) You may not use, copy, modify, alter or transfer the SOFTWARE, any copy thereof or its related documentation, in whole or in part, except as expressly provided in this Agreement.

3. TERM:

This license is effective until terminated. You may terminate this Agreement at any time by destroying the SOFTWARE and related documentation and all copies thereof. This license will also terminate if you fail to comply with any term or condition of this Agreement. Upon such termination, you agree to destroy all copies of the SOFTWARE and related documentation.

4. LIMITED WARRANTY:

Within ninety (90) days of your receipt of the SOFTWARE, Panasonic warrants that the storage media on which the SOFTWARE are furnished is free from defect in materials and workmanship under normal use, and that it will repair or at its option replace any defective media at no charge to you, provided that such defective media is returned to Panasonic within such ninety (90) days period.

5. LIMITATION OF LIABILITY:

EXCEPT AS STATED ABOVE, NEITHER PANASONIC NOR PANASONIC'S SUPPLIER MAKES OR PASSES ON TO YOU OR OTHER THIRD PARTY, ANY WARRANTY OR REPRESENTATION INCLUDING, BUT NOT LIMITED TO, THE IMPLIED WARRANTY OF MERCHANTABILITY AND FITNESS FOR A PARTICULAR PURPOSE. WITHOUT LIMITING THE GENERALITY OF THE FOREGOING, NEITHER PANASONIC NOR PANASONIC'S SUPPLIER WARRANTS THAT THE SOFTWARE WILL BE ERROR-FREE OR THAT IT WILL MEET YOUR REQUIREMENTS. NEITHER PANASONIC NOR PANASONIC'S SUPPLIER SHALL BE LIABLE FOR ANY DAMAGE SUFFERED BY YOU INCLUDING, BUT NOT LIMITED TO, CONSEQUENTIAL, INCIDENTAL SPECIAL OR PUNITIVE DAMAGES. THE ABOVE LIMITATIONS SHALL APPLY REGARDLESS OF THE FORM OF ACTION WHETHER IN CONTRACT, TORT (INCLUDING NEGLIGENCE), STRICT PRODUCT LIABILITY OR OTHERWISE, EVEN IF SUCH PARTY HAS BEEN ADVISED OF THE POSSIBILITY OF SUCH DAMAGES.

FOR USERS IN UNITED STATES

This equipment has been tested and found to comply with the limits for a Class B digital device, pursuant to Part 15 of the FCC Rules. These limits are designed to provide reasonable protection against harmful interference in a residential installation.

This equipment generates, uses, and can radiate radio frequency energy and, if not installed and used in accordance with the instructions, may cause harmful interference to radio communications.

However, there is no guarantee that interference will not occur in a particular installation. If this equipment does cause harmful interference to radio or television reception, which can be determined by turning the equipment off and on, the user is encouraged to try to correct the interference by one or more of the following measures:

- Reorient or relocate the receiving antenna.
- Increase the separation between the equipment and receiver.
- Connect the equipment into an outlet on a circuit different from that to which the receiver is connected.
- Consult the dealer or an experienced radio/TV technician for help.

The user may find the booklet "Something About Interference" available from FCC local regional offices helpful.

FCC Warning: To assure continued FCC emission limit compliance, the user must use the recommended shielded interfacing cable when connecting to a host computer. Also, any unauthorized changes or modifications to this equipment would void the user's authority to operate this device.

Technical Support Calls

If you have read this manual and tried the troubleshooting procedures and you are still having difficulty, please contact the reseller from which the unit was purchased. You may also call the end user technical support telephone number which is operational during East Coast business hours (9:00 AM to 7:00 PM). The end user technical support number is 1-888-744-2424. This number is available within the U.S. only.

Helpful Phone Numbers

To locate your nearest sales dealer	CALL 1-800-742-8086 ask for COLOR
To order consumables	CALL 1-800-222-0584
To order operating instructions/CD's	CALL 1-800-833-9626
To locate your nearest authorized service center	CALL 1-888-744-2424
For technical support	CALL 1-888-744-2424
Automated 24-hour support via Fax back	CALL 1-800-222-0584
Electronic bulletin board	CALL 1-201-863-7845
World Wide Web Technical & Driver Support	http://www.panasonic.com/alive

Contents

End-User License Agreement	4
For Your Safety	8

Chapter 1

Before You Start

Cautions	12
Features	14
System Requirements	15
PC	15
Interface	15
Minimum Space Requirements	16
Power Source	16
Unpacking	17
Part Names	18
Printer Panel Overview	19

Chapter 2

Setup

Setting Up the Printer	21
Preparing the Imaging Unit	21
Setting Up the Output Tray	22
Installing the Toner Cartridges	23
Loading Media	25
Loading Paper or Transparencies in the Media Tray	25
Margins and Print Area	28
Loading Media in the Multi-purpose Tray	29
Connecting the Printer to a Computer	33
Using a Parallel Interface Cable	34
Using a SCSI Cable	35
Power On	38
Printing a Test Page From the Printer Panel	39
Installing the KX-P8410 Software	40
Installing the Printer Driver and Utilities for Windows 3.1	41
Installing the Printer Driver and Utilities for Windows 95	42
Installing the Printer Driver and Utilities for Windows NT 4.0	45
Removing the KX-P8410 Software	51
Installing Panasonic Font Manager	52
Setting the Color Density	54

Chapter 3

Using the Printer

Menu Mode	59
Outline for Menus	60
Outline for Operation	62
Displaying the Panasonic KX-P8410 Window (for Windows 95 / 3.1)	63
Details Tab	66
Paper Tab	67
Graphics / Color Tab	69
Option Tab	72
Displaying the Panasonic KX-P8410 Default Document Properties Window (for Windows NT 4.0)	74
Page Setup Tab	76
Advanced Tab	78
Displaying the Panasonic KX-P8410 Properties Window (for Windows NT 4.0)	83
Ports Tab (SCSI port)	84
Sharing Tab	88
Device Settings Tab	91
Using the Hyper-Tetra Adjustment	93
Displaying the Hyper-Tetra Adjustment Window	93
Color Adjustment	94
Color Balance	96
Two-Sided Printing Using Microsoft Word 95	97

Chapter 4

Care and Maintenance

Cleaning	99
User Replaceable Components	103
Clearing a Jam	105
Troubleshooting	117
SCSI	127
Error Messages	130
Printer LCD Panel	130
Printer Driver For Windows 3.1	133
Printer Driver For Windows 95	135
Printer Driver For Windows NT 4.0	137
Status Display	139
Status Display Program	142
Printer Status Dialog Box	143
Repacking	144

Appendix

Specifications	153
Printer	153
Media	155
Software	160
Bidirectional Parallel Interface	161
SCSI Interface	162
Index	163

For Your Safety

General

Warning

- To prevent fire or shock hazard, do not expose this product to rain or any type of moisture.

Caution

- Do not open covers and do not attempt to repair the unit yourself. Refer servicing to qualified personnel.

Power Source

Warning

- The power source voltage of this unit is listed on the nameplate. Only plug the unit into an outlet with the proper voltage.
- When you operate this equipment, the outlet should be near the equipment and accessible.
- To ensure safe operation the AC cord supplied must be inserted into standard three-prong AC outlet which is effectively grounded (earthed) through the normal wiring.
- The fact that the equipment operates satisfactorily does not imply that the power point is grounded (earthed) and that the installation is completely safe. For your safety, if in any doubt about the effective grounding (earthing) of the power point, consult a qualified electrician.
- If the plug cannot be inserted into the AC outlet, contact a licensed electrician to replace the outlet with a properly grounded (earthed) one. Do not defeat the purpose of the grounding (earthing) plug (ex. do not use a conversion plug).

Laser Safety

Caution

- This printer utilizes a laser.
Use of controls or adjustments or performance of procedures other than those specified herein may result in hazardous radiation exposure.

Ozone Release

Warning

- Make sure that the printer is installed in a well ventilated room so as not to increase density of ozone in the air. Since ozone is heavier than air, it is recommended that air at floor level be ventilated.

Moving the Unit

The printer weighs approximately 47.9 kg {105.5 lbs.}. It must be handled by two people. Turn the power off and remove the power cord when handling the unit.

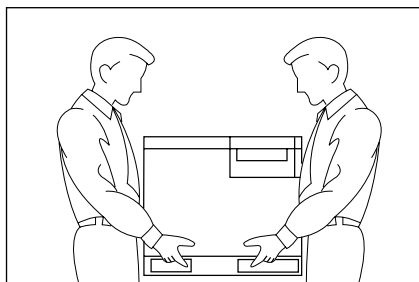

For Your Safety

Caution Labels

<p>DANGER: Invisible laser radiation when open and interlock defeated. AVOID DIRECT EXPOSURE TO BEAM.</p>	<p>CAUTION: Invisible laser radiation when open and interlocks defeated. AVOID EXPOSURE TO BEAM.</p>	<p>VORSICHT: Unsichtbare Laserstrahlung, wenn Abdeckung geöffnet und Sicherheitsverriegelung überbrückt. NICHT DEM STRAHL AUSSETZEN.</p>	<p>ATTENTION: Rayonnement laser invisible dangereux en cas d'ouverture et lorsque la sécurité est neutralisée. EXPOSITION DANGEREUSE AU FAISCEAU.</p>		
<p>PELIGRO: Cuando se abre y se invalida el bloqueo, se producen radiaciones invisibles de láser. EVÍTESE LA EXPOSICIÓN A TALES RAYOS.</p>	<p>VARNING: Osynlig laserstrålning när denna del är öppnad och spärrar är urkopplade. STRÅLEN ÄR FARLIG.</p>	<p>VARO! Näkymätöntä avattaessa ja suojalukitus ohitettaessa olet alltiina lasersäteilylle. ÄLÄ KATSO SÄTEESEEN.</p>	<p>VARNING: Osynlig laserstrålning när denna del är öppnad och spärran är urkopplad. BETRAKTA EJ STRÅLEN.</p>		<p>ADVARSEL: Usynlig laserstrålning ved åbning når sikkerhedsafbrydere er ude af funktion. UNDGÅ UDSÆTTELSE FOR STRÅLING.</p>

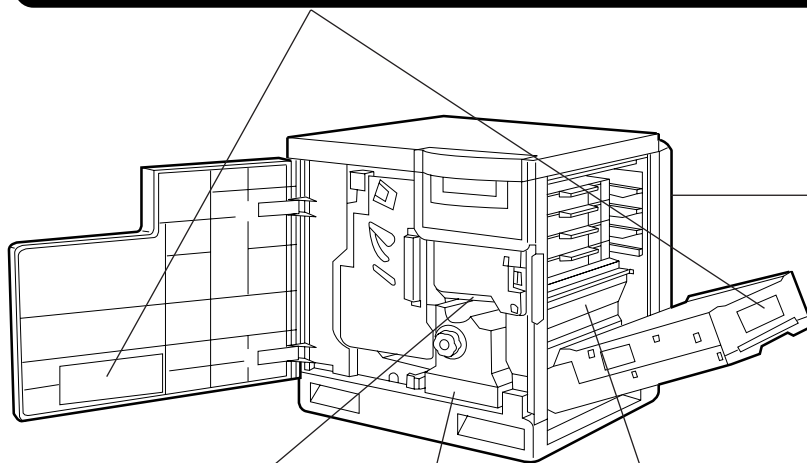

(220-240 VAC equipment)

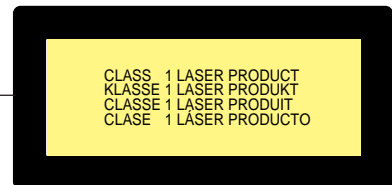

Laser diode properties

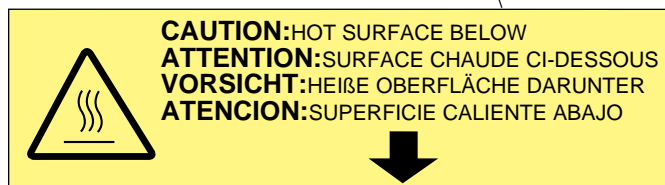
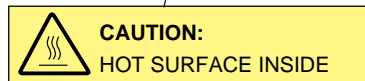

Laser output : 5 mW max
Wavelength : 780 nm
Emission duration : Continuous



FOR USERS IN U.K.

IMPORTANT:
FOR YOUR SAFETY PLEASE READ THE FOLLOWING TEXT CAREFULLY

This printer is supplied with a moulded three pin mains plug each for your safety and convenience. A 13 amp fuse is fitted in this plug. Should the fuse need to be replaced please ensure that the replacement fuse has a rating of 13 amps and that it is approved by ASTA or BSI to BS 1362.

Check for the ASTA mark  or the BSI mark  on the body of the fuse.

If the plug contains a removable fuse cover you must ensure that it is refitted when the fuse is replaced. If you lose the fuse cover the plug must not be used until a replacement cover is obtained. A replacement fuse cover can be purchased from your local Panasonic Dealer.

IF THE FITTED MOULDED PLUG IS UNSUITABLE FOR THE SOCKET OUTLET IN YOUR HOME THEN THE FUSE SHOULD BE REMOVED AND THE PLUG CUT OFF AND DISPOSED OF SAFELY. THERE IS A DANGER OF SEVERE ELECTRICAL SHOCK IF THE CUT OFF PLUG IS INSERTED INTO ANY 13 AMP SOCKET.

If a new plug is to be fitted please observe the wiring code as shown below. If in any doubt please consult a qualified electrician.

WARNING: THIS APPLIANCE MUST BE EARTHED.

IMPORTANT: The wires in this mains lead are coloured in accordance with the following code.

Green-and-Yellow: Earth Blue: Neutral Brown: Live

As the colours of the wire in the mains lead of this appliance may not correspond with the coloured markings identifying the terminals in your plug, proceed as follows.

The wire which is coloured GREEN-AND-YELLOW must be connected to the terminal in the plug which is marked with the letter E or by the Earth symbol , or coloured GREEN or GREEN-AND-YELLOW.

The wire which is coloured BLUE must be connected to the terminal in the plug which is marked with the letter N or coloured BLACK.

The wire which is coloured BROWN must be connected to the terminal in the plug which is marked with the letter L or coloured RED.

How to replace the fuse: Open the fuse compartment with a screwdriver and replace the fuse.

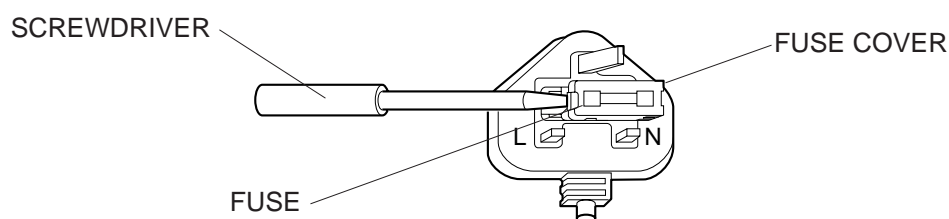

N52



FOR USERS IN AUSTRALIA

This mark shows that the product complies with AS/NZS 3548.

Before You Start

Cautions

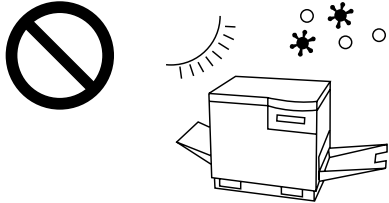
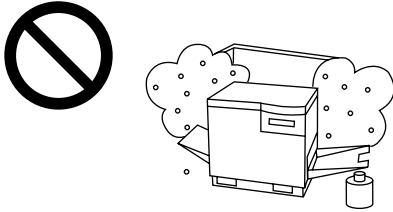
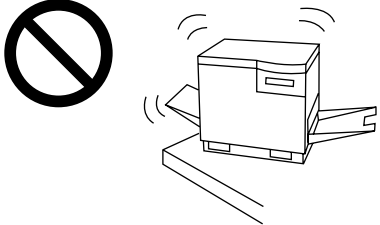
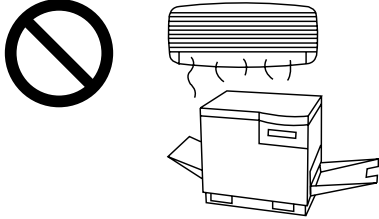
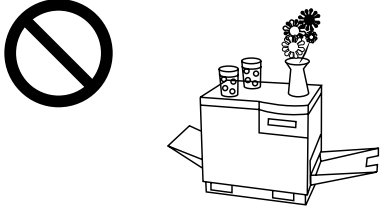
To avoid machine malfunction, do not use the equipment under the following conditions:

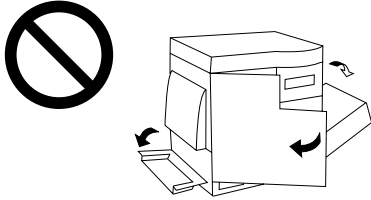
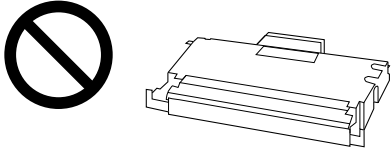
 <ul style="list-style-type: none">• Direct exposure to sunlight• Extremely high or low temperature [temperature range: 10°C to 32.5°C (50°F to 90.5°F)]• Extremely high or low humidity (humidity range: 20% to 80% RH)• Condensation due to rapid change of temperature	 <ul style="list-style-type: none">• Areas of poor ventilation• Areas of high dust or chemical fume concentration (solvent etc.)	
 <ul style="list-style-type: none">• Unstable or unlevel surfaces	 <ul style="list-style-type: none">• Directly in front of air conditioning vents	 <ul style="list-style-type: none">• Liquids near the equipment
 <ul style="list-style-type: none">• Too much media/document which exceeds the limit mark on the guide of the tray.	 <ul style="list-style-type: none">• Front/right/left doors opened while the printer is operating; it may cause a media jam.	 <p>Not genuine toner</p> <ul style="list-style-type: none">• Any toner other than genuine Panasonic toner. It may damage the printer.

■CD-ROM

To prevent the CD-ROMs from accidental damages:

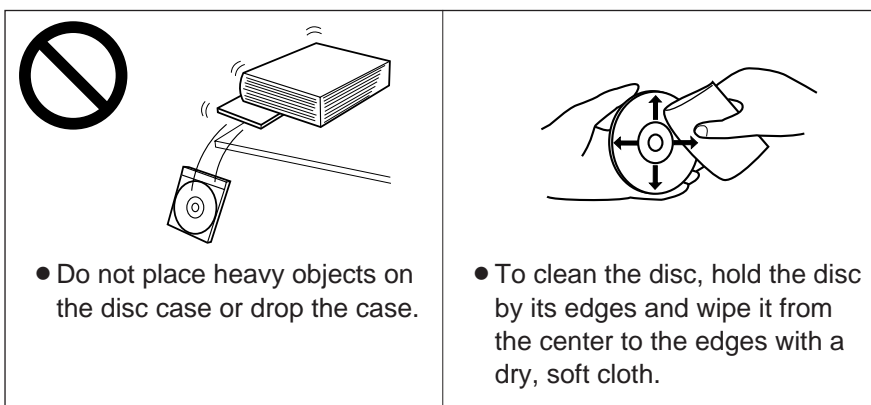

■Static Electricity Damage

To prevent static electricity damage to any of the following components, touch a grounded metal surface, such as the printer's bare metal frame prior to touching the component.

- The interface connectors : SCSI, parallel and optional network
- Electrical components, connectors inside the printer and any components on the optional board (RAM Expansion Board or Ethernet Card)
- The connector pins on the optional 2nd cassette feeder for the printer

■Interface Cable

Always use a shielded interface cable. Use of an unshielded cable can result in radio interference with data.

■Waste Disposal Method

Waste material may be dumped or incinerated under conditions which meet all federal, state and local environmental regulations.

Before You Start

Features

The KX-P8410 Color Laser Printer provides fast, high-quality color printing on plain paper, plus the ease of operation and high performance you expect from a laser printer.

Some of its features include:

■ **High quality**

Resolution

Maximum 1200 dpi*

(*with SIMM options installed)

■ **High speed**

Continuous printing on letter size/A4 size paper

Full-color mode: Maximum 3.5 ppm (pages per minute)

Monochrome mode: Maximum 14 ppm

■ **Easy operation**

Printer driver

Easily print full-color documents.

System Requirements

PC

To operate the KX-P8410 effectively, see the following.

CPU:	More than Pentium or Pentium PRO (133 MHz or faster CPU is recommended.)
Operating System:	Windows® 3.1* ¹ , Windows 95* ² or Windows NT® 4.0* ³ (Intel Only)
RAM:	16 MB or more (More than 32 MB is recommended.)
Free disk space:	100 MB or more
Virtual memory:	16 MB or more (More than 32 MB is recommended.) for Windows 3.1 / 95 50 MB or more (More than 100 MB is recommended.) for Windows NT 4.0
Display:	Video card that can display more than 256 colors. (A video card that can display more than 32,000 colors is recommended.)
Drive:	CD-ROM drive

*¹ Microsoft® Windows® operating system Version 3.1 (hereafter Windows 3.1)

*² Microsoft® Windows® 95 operating system (hereafter Windows 95)

*³ Microsoft® Windows NT® Workstation operating system, and Microsoft®
Windows NT® Server network operating system Version 4.0
(hereafter Windows NT 4.0)

Interface

One of the following can be used:

■ Parallel interface requirement

Interface	Based on the IEEE P1284-C standard (An ECP compatible parallel port is recommended for Windows 95. To turn on the ECP mode, use the computer's BIOS setup. Refer to the computer's manual for details.)
-----------	---

■ SCSI interface requirements

SCSI cable	SCSI-2 (FAST SCSI) compatible ( P. 162)
SCSI-2 board	ASPI Manager compatible SCSI-2 board (Adaptec AHA-2940 is recommended.)
ASPI manager	ASPI Manager is required. (Refer to the SCSI-2 board manual.)

Before You Start

Minimum Space Requirements

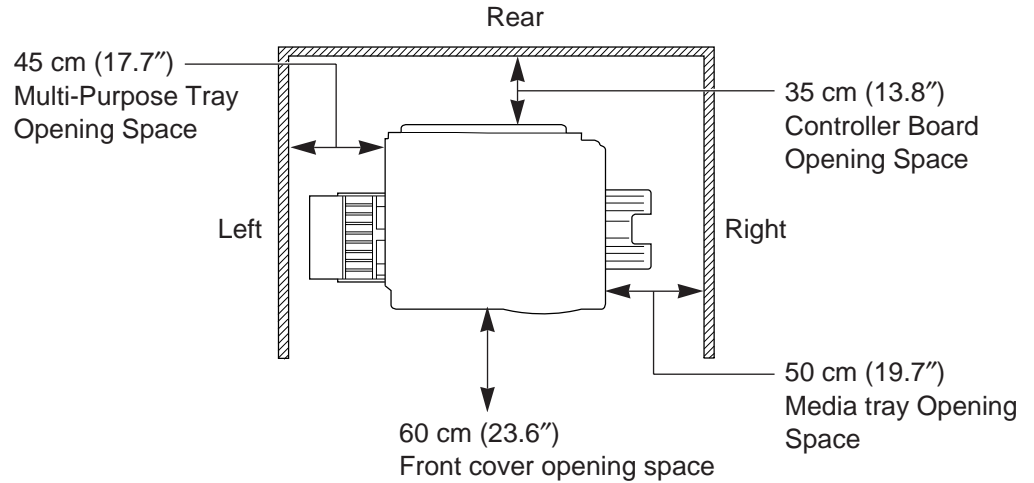

Power Source

- The voltage level of the power source must not vary more than $\pm 10\%$ from the voltage level marked on the nameplate (located on the back of the unit).
- Do not use an extension cord.
- Do not use a line conditioner, transient suppressor or surge protector as it may cause a machine error.

Unpacking

Make sure that all of the items shown below were provided and have not been damaged. Report damage or shortages to the reseller from which the unit was purchased. [Page 3](#) includes an area for recording important information such as the name of reseller, serial number, and date of purchase.

Note:

- *Save the original carton and packing materials for future shipping and transporting of the unit. They have been specifically designed to protect the equipment during shipment.*

1. Printer (Color imaging unit, Fuser unit, Paper tray and Output tray are included.)
2. Toner cartridges (black, cyan, magenta, and yellow)
3. Power cord
4. KX-P8410 Driver & Utility CD-ROM
5. KX-P8410 Operating Manual CD-ROM
6. Color Calibration Card
7. Setup manual

1

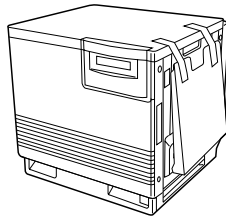

2

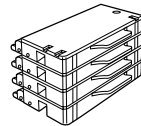

3



4



5



6

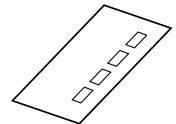

7

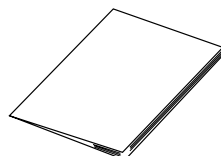

Before You Start

Part Names

■ Front side view

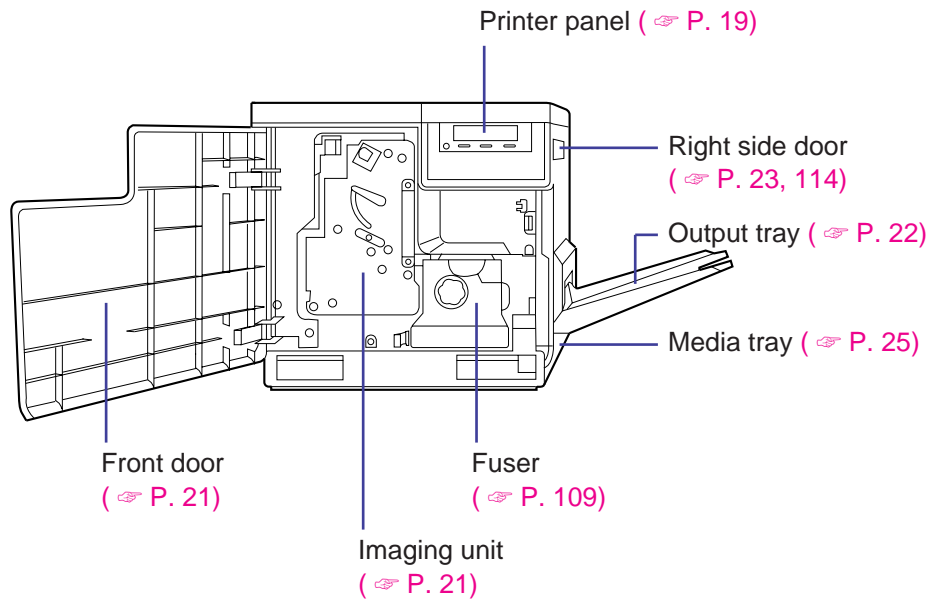

■ Rear side view

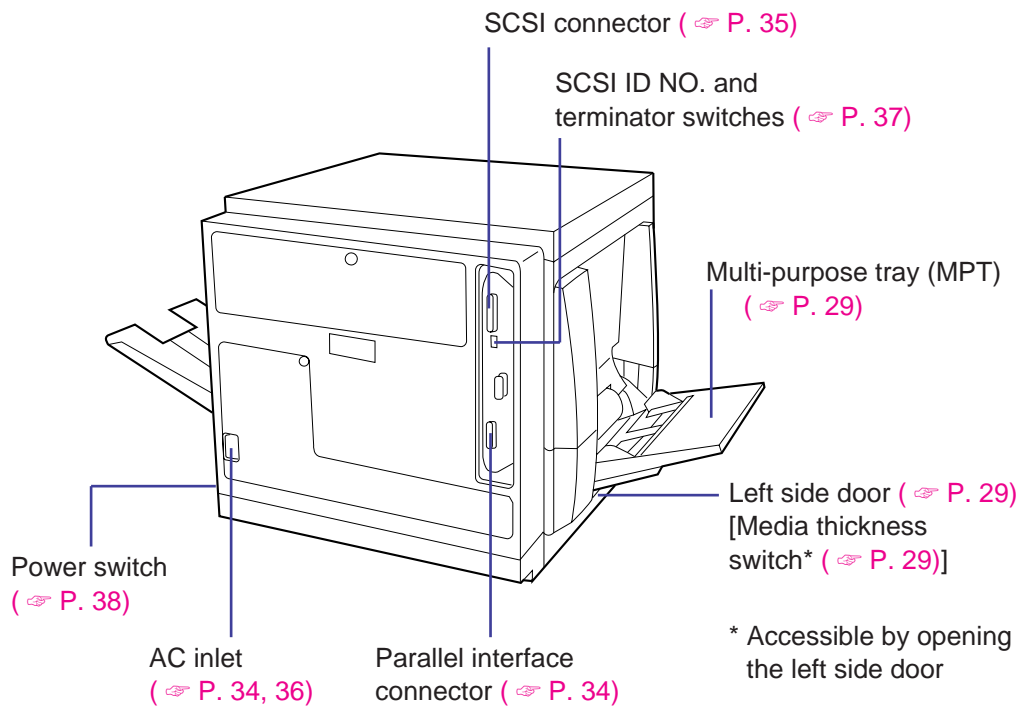

Printer Panel Overview

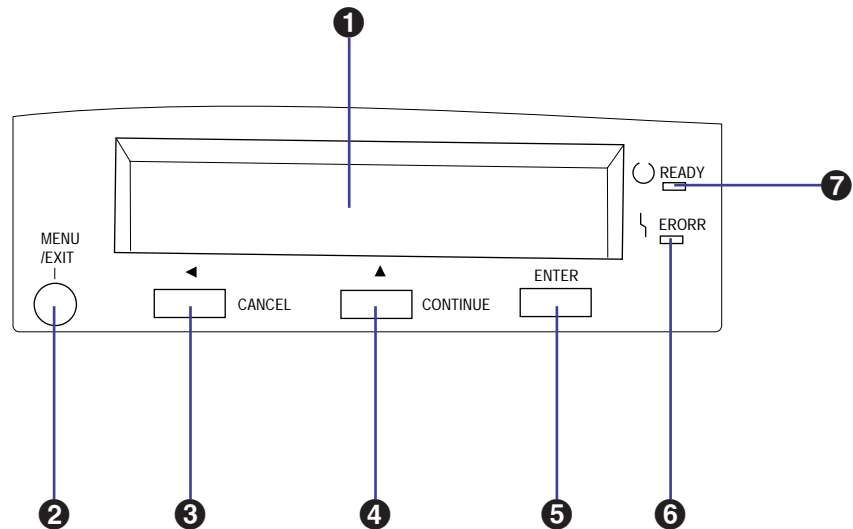

1 LCD (Liquid Crystal Display) panel

The printer LCD has two 24-character lines to display the printer's status/error messages or menu settings.

2 MENU/EXIT button

- When the printer is ready, pressing this button enters the Menu mode.
- Pressing this button exits the Menu mode.

3 ◀/CANCEL button

- Pressing this button for 2 or more seconds cancels the data in the printer.
- When the printer is in the Menu mode, pressing this button:
 - Displays the previous menu, item or selection.
 - Decreases the current numerical value of the selection.
 - Moves the cursor to left.

4 ▲/CONTINUE button

- When the printer is in the Menu mode, pressing this button:
 - Displays the next menu, item or selection.
 - Increases the current numerical value of the selection.
- When error messages such as "Memory Overflow" or "SCSI Communication Error" are displayed on the LCD, press this button to recover from an error situation.

5 ENTER button

This button is effective only when the printer is in the Menu mode. Pressing this button:

- Enters a sub - menu.
- Activates a selection.

Before You Start

⑥ ERROR indicator (orange)

- ON: an internal error (Call for Service Error) has occurred.
- Blinking: user correctable error, such as media jam, open door, or a missing replaceable component (e.g. Toner) has occurred.

⑦ READY indicator (green)

- ON: the printer is ready for operation.
- Blinking: the printer is warming up or in the Menu mode.
- Blinking fast: the printer is printing.

Setup

Setting Up the Printer

Preparing the Imaging Unit

- 1 Open the front door.

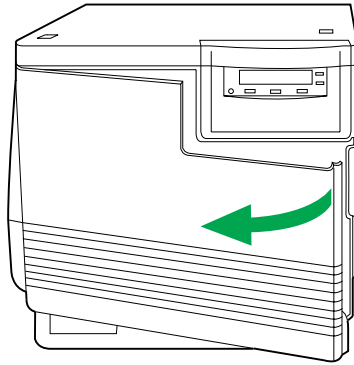

- 2 Turn the upper green lever clockwise until it stops and the arrows are aligned. (This tightens the internal belts to ready the unit for printing.)

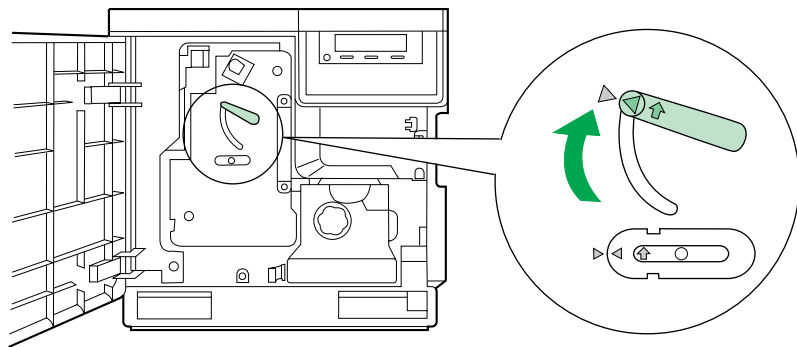

- 3 Close the front door.

Setting Up the Output Tray

- 1** Remove the adhesive tape that holds the output tray against the printer.

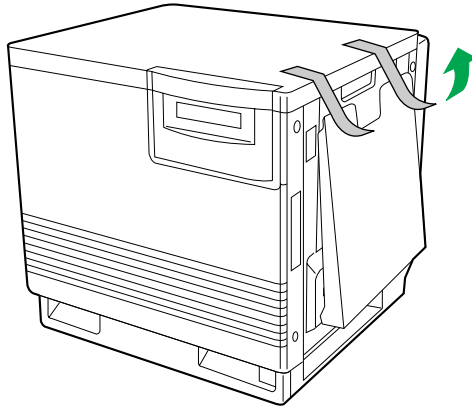

- 2** Lower the tray to the operating position.

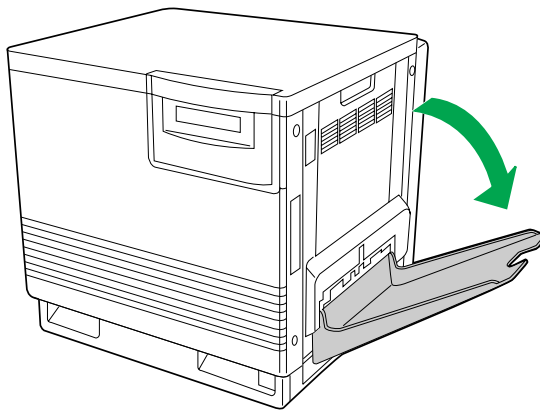

Installing the Toner Cartridges

Note:

- The toner cartridges that are shipped with the printer are starter cartridges. They are installed in exactly the same manner as the optional cartridges; the only difference is that the starter cartridges have less toner. (The page life expectancy is 3,000 pages, which is based on a 5% image area.)

- 1** Remove the packaging from the toner cartridge.
- 2** Remove the shipping cover from the cartridge.

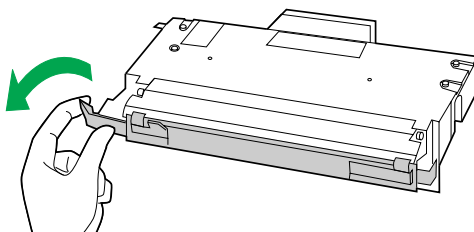

Caution:

- To avoid possible toner spillage, do not tilt cartridge.

Note:

- Save all packing material for shipping purpose.

- 3** Open the right side door.

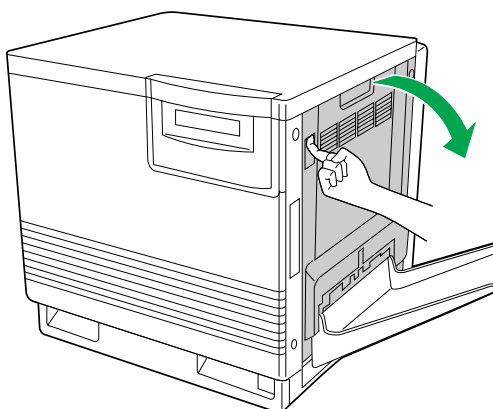

Caution:

- Do not leave the right side door open for more than 1 minute; the imaging unit will be exposed to light and could be damaged.

- 4** Insert the toner cartridge in the appropriately labeled slot.
From top to bottom, the order of the color toner cartridges is BLACK, CYAN, MAGENTA, YELLOW.

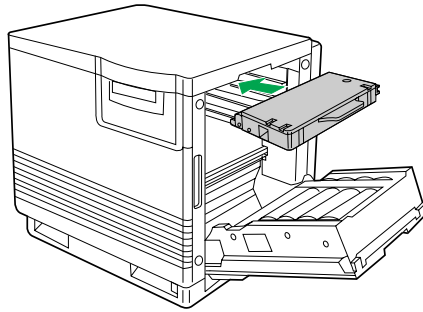

- 5** Repeat steps 1, 2 and 4 for each toner cartridge.
When you have installed all the toner cartridges, go to step 6.

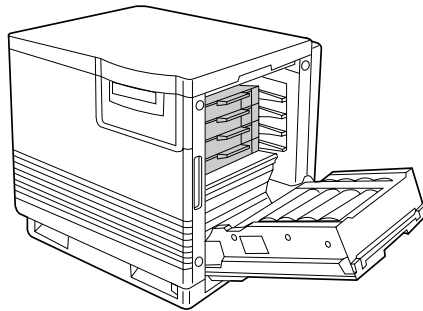

- 6** Close the right side door.

Loading Media

Loading Paper or Transparencies in the Media Tray

The printer uses five different trays:

Tray	Size
A4 Paper	210 mm x 297 mm (8.3" x 11.7")
A4 Transparency	210 mm x 297 mm (8.3" x 11.7")
Letter Paper	216 mm x 279 mm (8.5" x 11")
Letter Transparency	216 mm x 279 mm (8.5" x 11")
Legal Paper	216 mm x 356 mm (8.5" x 14")

Notes:

- Make sure that you load the correct media. Each tray is designed and labeled for **only** paper or transparency. If you load the incorrect media type in a tray, it may cause a jam.
- If you have the 2nd Cassette Feeder installed:
 - If you wish to use the automatic cassette-switching feature (a large print job, for example), make sure that all trays in the printer are the **same** media type and size.
 - The transparency tray should only be inserted in the upper or middle tray slots.

The printer is shipped with a media tray (either Letter paper or A4 paper) installed.

- 1** Pull the media tray out of the printer.

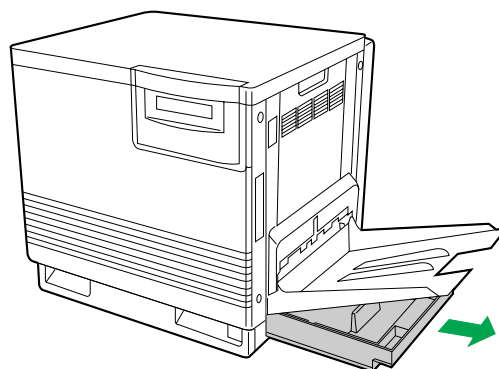

- 2** Remove all packaging materials from inside the media tray; refer to the instruction sheet attached to the tray.

- 3** Push down on the metal plate until it clicks, locking it in place.

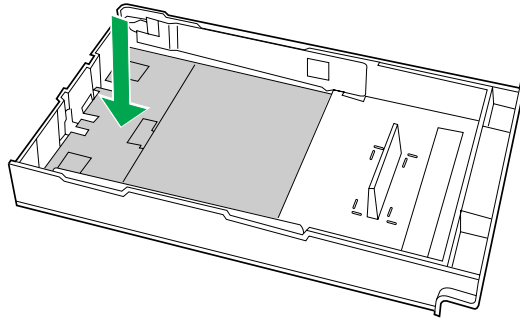

- 4** Fan the media (paper/transparencies), then tap it on a level surface to avoid media jams or skewed printing.

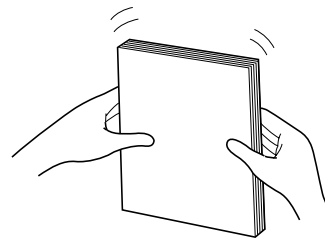

Notes:

- To optimize your printer's performance, always use clean, unused media.
- Be careful not to leave fingerprints on the media, which can result in a smudged print.
- Reusing media that has been fed through the printer once (for example, after jams) can reduce the life of the consumables and paper path components.
- The recommended transparency is 3M CG3700. If the print quality is poor, print on the other side.

5 Place the media in the tray under the hooks.

The height of media should not exceed the limit mark on the tray, or it may cause a jam.

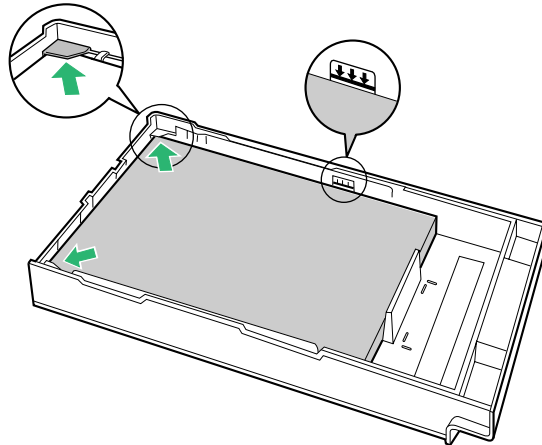

Notes:

- Load media with the print side down. Most media has instructions recommending the side to be printed first.
- Do not mix different types or thicknesses of media in the media tray at one time; this may cause a jam.

6 Slide the media tray completely into the slot.

Margins and Print Area

When the image is printed on the media, the image (print area) is a bit smaller than the media size. You may need to adjust the page margins in the application software to match the print area.

The following table and illustrations show the page sizes, the largest print areas, and the margins for the media sizes supported on this printer.

Media	Page size	Print area	Margins		
			Top	Bottom	Sides
Letter	216 mm x 279 mm (8.5" x 11")	208 mm x 269 mm (8.2" x 10.6")	5.6 mm (0.22")	5.6 mm (0.22")	3.6 mm (0.14")
A4	210 mm x 297 mm (8.3" x 11.7")	200 mm x 287 mm (7.9" x 11.3")	5.1 mm (0.2")	4.7 mm (0.19")	4.7 mm (0.19")
Legal	216 mm x 356 mm (8.5" x 14")	208 mm x 343 mm (8.2" x 13.5")	5.8 mm (0.23")	5.8 mm (0.23")	3.6 mm (0.14")

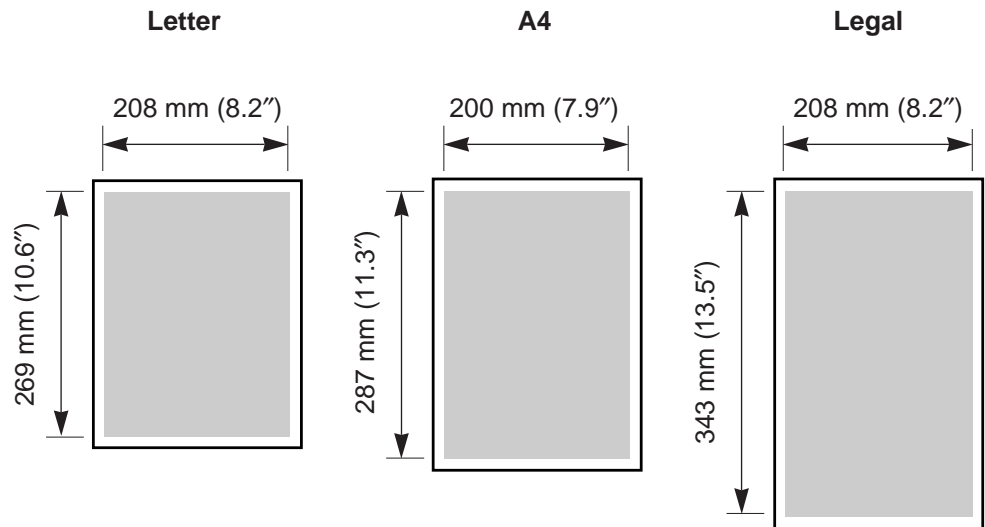

Loading Media in the Multi-purpose Tray

The multi-purpose tray (MPT) serves as an additional tray for loading any type of media that ranges in size from 91 mm x 254 mm to 216 mm x 356 mm (3.6" x 10" to 8.5" x 14"). Use it to load a single sheet or a stack of media, depending on the media's type and thickness.

Use the multi-purpose tray to accomplish the following:

Print on standard and special media

- Standard media
 - Laser paper [75 to 165 g/m² (20 to 44 lbs.)]
- Special media
 - Labels
 - Envelope (#10 size) [Black Text only]
 - Transparency (The print quality may not be stable. Use the media tray for best reliability.)

Two-sided printing (doubles-sided) on laser paper

You should not expect the same print quality and reliability that you get with one-sided printing. For details, refer to [page 156](#).

Setting media thickness switch

Because the printer accommodates various media weights from the multi-purpose tray, media thickness can be manually selected for the most reliable paper-picking. Follow these steps:

- 1** Open the left side door (❶). The green media thickness switch is located on the paper feeder and has three settings:

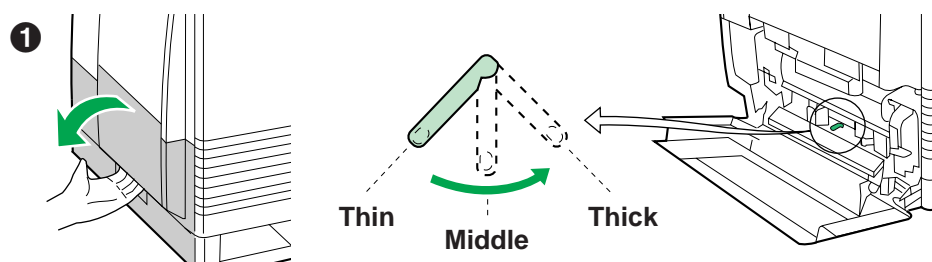

- 2** Move the switch to the desired setting.

Switch setting	Media
Thin (Default)	Laser paper 75 to 90 g/m ² (20 to 24 lbs.)
Middle	Laser paper 91 to 123 g/m ² (25 to 32 lbs.) Transparency, Label
Thick	Laser paper 124 to 165 g/m ² (33 to 44 lbs.) Envelope

- 3** Close the left side door.

■ Loading Paper, Transparency

Notes:

- Reusing media that has been fed through the printer (for example, after jams) can reduce the life of the consumables and paper path components.
- When printing legal size using the multi-purpose tray, backside marking may occur. If this occurs, use the legal cassette.

For detailed information on media, refer to [page 155](#).

1 Set the media thickness switch ([P. 29](#)).

2 **1** Open the Multi-purpose tray.

2 **2** Extend the media support by sliding it outward.

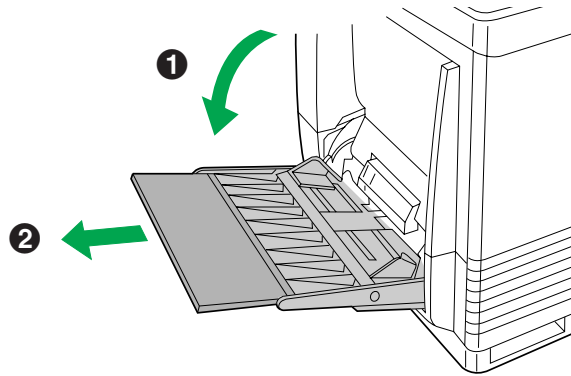

3 Separate the media guides to the approximate width of the media.

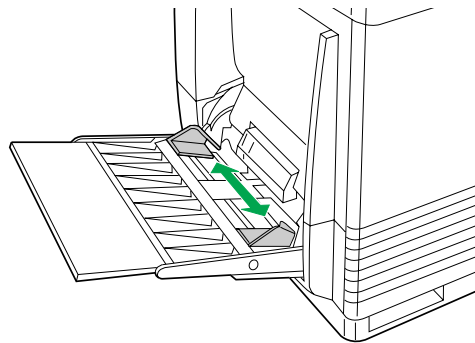

4 Fan the media, and then tap it on a level surface to avoid media jams or skewed printing.



- 5** Insert the media with the printing side up into the multi-purpose tray.

The height of media should not exceed the limit mark on the left guide, or it may cause a media jam.

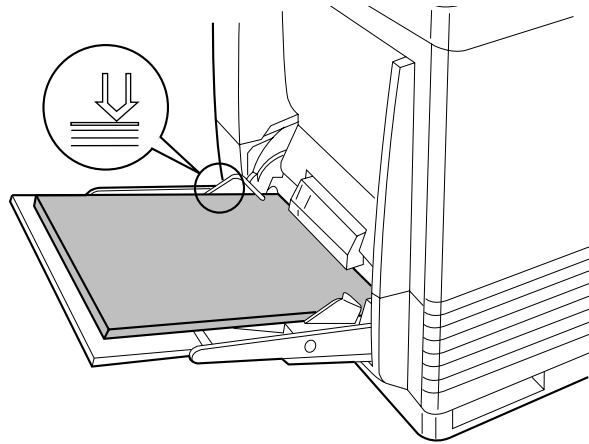

- 6** Adjust the media guides to the media size.
- 7** Use the printer driver to select the multi-purpose tray.

■ Loading an Envelope

Do not insert more than one envelope at a time. Only black text can be printed on envelopes. For more detailed information on envelopes, refer to [page 158](#).

- 1** Set the media thickness switch ([P. 29](#)).
- 2** Adjust the media guides to the width of the envelope.
- 3** Insert the envelope with the short end entering the printer first and the printing side facing up. The edge where the stamp is located enters the printer last.

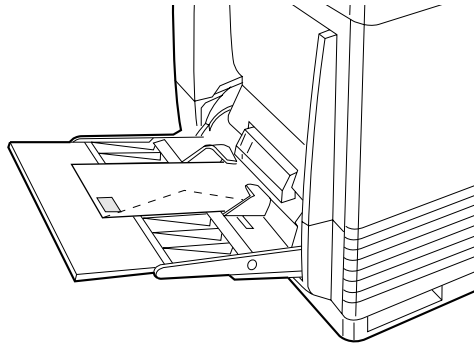

- 4** Use the printer driver to select Envelope in the Paper size menu and the Paper source menu.

■ Loading Labels

For detailed information on labels, refer to [page 157](#).

- 1** Set the media thickness switch ([P. 29](#)).
- 2** Adjust the media guides to the width of the label sheets.
- 3** Insert the label sheets in the multi-purpose tray with the printing side up and the top of the sheets enter first.
The height of labels should not exceed the limit mark on the guide.
- 4** Use the printer driver to select Label.

Connecting the Printer to a Computer

Only one PC can be directly connected to your printer.

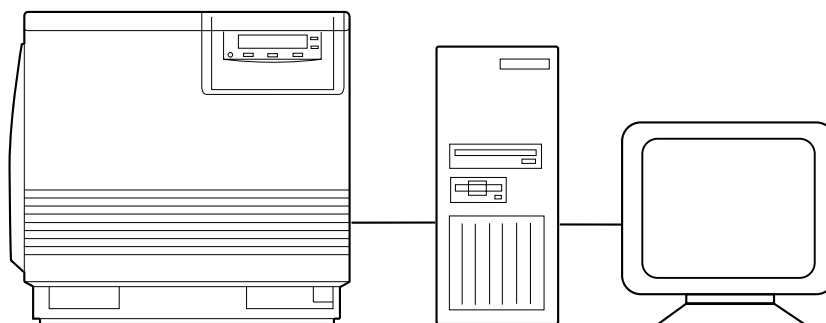

Using a Parallel Interface Cable

If you do not have a parallel interface cable, you will need to purchase one from your local computer store or dealer ([P. 161 for Parallel Interface specifications](#)).

- 1** Make sure the computer, printer and the other connected peripheral devices are turned off.
- 2** Connect the parallel interface cable to the computer's parallel interface connector and the printer's parallel interface connector.

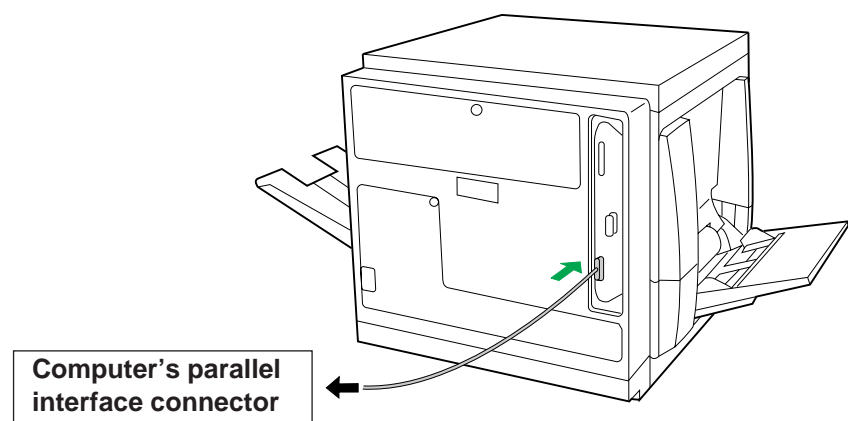

Notes:

- The actual connector on the computer may differ depending on the manufacturer of the computer.
- If the cable is connected to the PC via a printer buffer or selector, the printer may not print.

- 3** Connect the power cord to the printer's AC inlet and to an AC outlet.

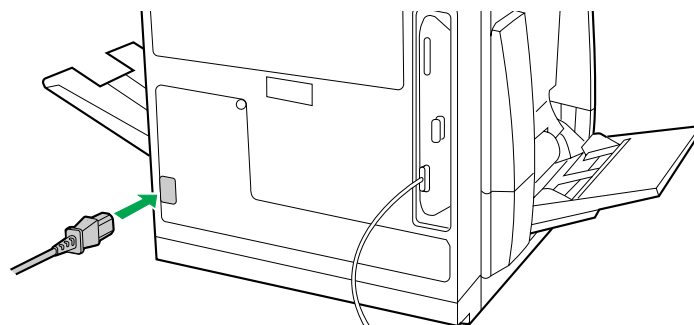

Using a SCSI Cable

Note for Terminator setting:

- The printer must be the last device in the chain. The terminator setting of all other devices in the chain must be off.

1 Make sure the computer, printer and the other connected peripheral devices are turned off.

2 Connect the SCSI cable to the computer's SCSI connector and the printer's SCSI connector.

- A SCSI-2 board must be installed in the computer.
If you do not have a SCSI-2 board or a SCSI interface cable, you will need to purchase one from your local computer store or dealer (☞ P. 15, 162 "SCSI Interface" specifications).

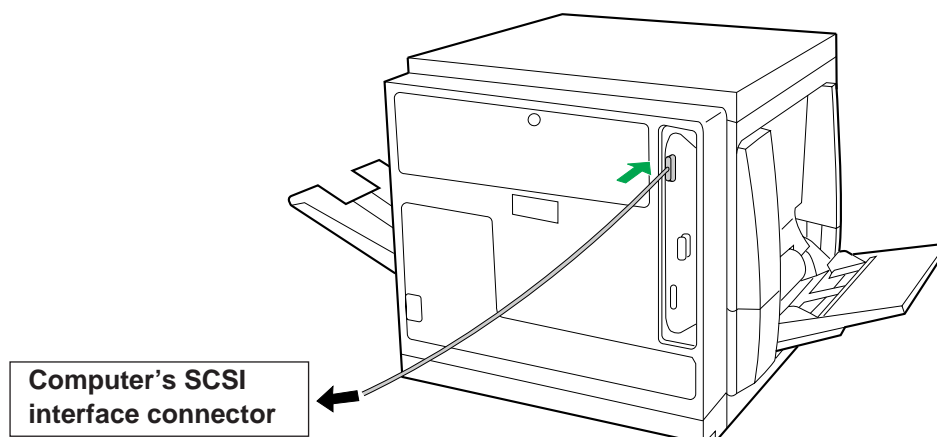

3 Make sure the SCSI ID No. of the printer is 1 (default setting).

- If you have other devices connected to the computer, make sure that each SCSI device has a different ID No.
- To change the printer's ID No., use the ID No. switches (#1, #2, #3) located on the back of the printer. Also refer to Table 1 on page 37.

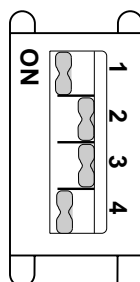

Setup

- 4** Make sure the terminator switch (#4) of the printer is set to ON (default setting).
- 5** Connect the power cord to the printer's AC inlet and to an AC outlet.

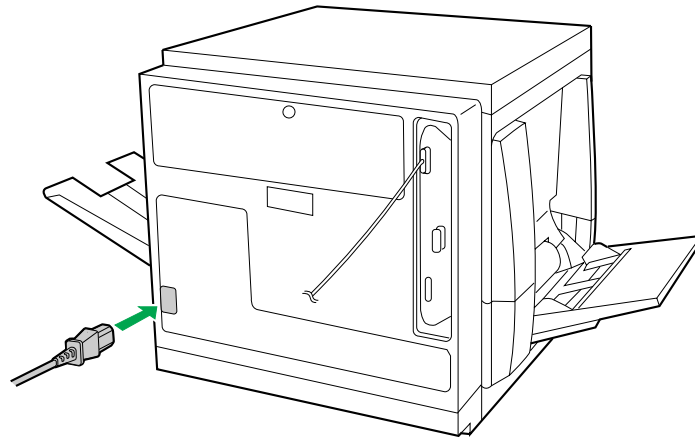

■Setting the SCSI ID Number

In most cases, there is no need to change the default settings. However, if you have other peripheral devices connected in a SCSI chain, check if their ID numbers conflict with that of the printer. Be sure to choose an unassigned ID number.

ID number can be changed by using the SCSI ID No. switches (#1, #2, #3) [ Table 1 below].

Table 1

ID No.	SCSI ID No. switches		
	#1	#2	#3
0	OFF	OFF	OFF
1	ON	OFF	OFF
2	OFF	ON	OFF
3	ON	ON	OFF
4	OFF	OFF	ON
5	ON	OFF	ON
6	OFF	ON	ON
7	ON	ON	ON

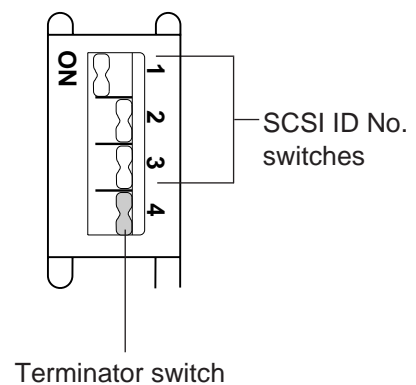

■Setting the Terminator

The terminator setting can be changed by using the terminator switch (#4).

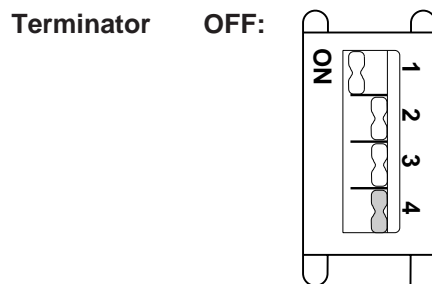
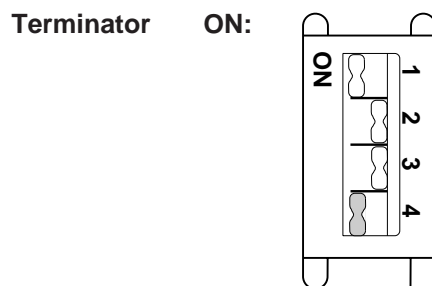

Power On

- 1 Turn ON the printer, then the computer.

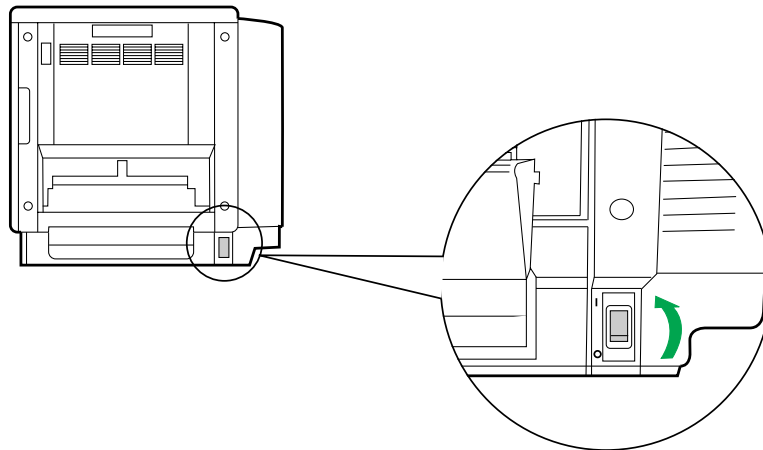

- 2
 - 1 The READY indicator on the printer starts flashing and “**Initializing**” is displayed on the printer LCD panel.
 - 2 After approximately 5 minutes, the printer’s READY indicator is illuminated and “**Ready**” is displayed on the printer LCD panel.

The printer is ready for printing.

Note:

- When you power on your system for the first time, if “New Hardware Found” is displayed on the computer screen, refer to [page 43](#).

Printing a Test Page From the Printer Panel

The test page provides general information on printer settings and configuration. Make sure the printer is ready and paper is loaded. Use the following procedure to print a test page.

- 1 Press the **MENU/EXIT** button to enter the **Menu Mode**.

```
Menu Mode
Test Page
```

- 2 Press the **ENTER** button.

```
Test Page
Configuration Page
```

- 3 Press the **ENTER** button again.
The printer will start printing a configuration page.

(Example)

```

                                Panasonic Color Laser Printer

Model Name                       : KX-P8410
Printer Rom Version No.          : V0XX : XXXXXX
Installed Memory                  : 008 MBytes
Installed Cassette                : Media Tray - Letter

< Panel Settings >

System Setting                    Energy Star           on
                                  Auto Continue          off
                                  Data Time Out          off

Maintenance                       Page Count           0000000000
                                  Color Imaging Unit    000%
                                  Transfer Unit          000%
                                  Fuser Unit             000%
                                  Oil Supply Roll         000%

Color Calibration                 OFFSET              00
                                  CYAN                 00
                                  MAGENTA              00
                                  YELLOW                00
                                  BLACK                 00

(C) 1996-1997 Kyushu Matsushita Electric Co.,Ltd.
```

Installing the KX-P8410 Software

The KX-P8410 software installation will create the following.

- Printer driver for Windows 3.1, Windows 95 or Windows NT 4.0 ([P. 41, 42, 45](#))
- Status Display for Windows 3.1, Windows 95 or Windows NT 4.0 ([P. 142](#))

Note:

- *If you are using Windows 3.1, disable or uninstall any application software's printer status to prevent conflicts with the KX-P8410 Status Display for Windows 3.1.*
- *When reinstalling the KX-P8410 software, do it immediately after restarting Windows.*

Installing the Printer Driver and Utilities for Windows 3.1

- 1** Start Windows 3.1.
- 2** Quit all applications.
- 3** Insert the **KX-P8410 Driver & Utility CD-ROM** into your computer's CD-ROM drive.
- 4** Click **File** from the **Program Manager**, then click **Run...**.
- 5** Click **Browse** and select your CD-ROM drive from the [Drives:] box.
- 6** Select **Setup.exe**, and click **OK**.
- 7** Click **OK**.
The Installer starts.
- 8** Follow the instructions on the screen to complete the installation.

Installing the Printer Driver and Utilities for Windows 95

- 1** Start Windows 95.
- 2** Quit all applications.
- 3** Click **Start**, move the pointer to **Settings**, then click **Control Panel**.
The Control Panel window is displayed.
- 4** Double click **Add/Remove Programs**.
The Add/Remove Program Properties window is displayed.
- 5** Click **Install**.
The Install Program From Floppy Disk or CD-ROM window is displayed.
- 6** Insert the **KX-P8410 Driver & Utility CD-ROM** into CD-ROM drive.
- 7** Click **Next>**.
The Run Installation Program window is displayed.
- 8** Click **Finish**.
Wait until the Panasonic KX-P8410 Utilities Welcome window is displayed.
- 9** Follow the instructions on the screen to complete the installation.
After installation, restart your system.

Note:

- *During installation, when "Setup is adding icon to the Printer folder. Please wait several minutes" is displayed, the processing may take approximately 5 to 10 minutes to complete depending on the system.*

■ Using Plug and Play

- 1** Turn on the printer.
- 2** Turn on the computer and start Windows 95.
The New Hardware Found window is displayed for a few seconds, then the Update Device Driver Wizard window is displayed.
- 3** Insert the **KX-P8410 Driver & Utility CD-ROM** into CD-ROM drive.
- 4** Click **Next>**.
“Windows was unable to locate a driver for this device” is displayed.
- 5** Click **Other Locations...**.
- 6** Type in your CD-ROM drive name followed by **:Win95\Disk2** (example; **D:\Win95\Disk2**) in the **Location** field and click **OK**.
- 7** Click **Finish**.
The Insert Disk window is displayed.
- 8** Click **OK**.
The Copying Files window is displayed.
- 9** Type in your CD-ROM drive name followed by **:Win95\Disk2** (example; **D:\Win95\Disk2**) in the **Copy File from** field and click **OK**.
- 10** Click **OK**.
The Open window is displayed.
- 11** Select **SETUP.EXE** included on the **KX-P8410 Driver & Utility CD-ROM** in your CD-ROM drive and then click **Open**.
Wait until the Panasonic KX-P8410 Utilities Welcome windows is displayed.
- 12** Follow the instructions on the screen to complete the installation.
After installation, restart your system.

Note:

- The Plug and Play installation procedure varies depending on the version of Windows 95. Refer to Help in Windows 95.

■ Using Add Printer

- 1** Start Windows 95.
- 2** Quit all applications.
- 3** Click **Start**, move the pointer to **Settings**, then click **Printers**.
The Printers window is displayed.
- 4** Double click the **Add Printer** icon.
- 5** Install the **KX-P8410 Driver & Utility CD-ROM** into CD-ROM drive.
- 6** Click **Next>**.
- 7** Select **Local printer** or **Network printer** and then click **Next>**.
- 8** Click **Have Disk...**.
- 9** Type in your CD-ROM drive name followed by **:Win95\Disk2** (example; **D:\Win95\Disk2**) in the **Install From disk** field and click **OK**.
- 10** Click **Next>**.
- 11** Follow the instructions on the screen to complete the installation.
After installation, restart your system.

Notes:

- The above "Using Add Printer" procedure installs only the printer driver. It does not install the Status Display program.
- After installing the printer driver, it will take several minutes for the printer to register and display in Printers Folder.

Installing the Printer Driver and Utilities for Windows NT 4.0

- 1** Start Windows NT 4.0.
- 2** Quit all applications.
- 3** Click **Start**, move the pointer to **Settings**, then click **Control Panel**.
The Control Panel window is displayed.
- 4** Double click **Add/Remove Programs**.
The Add/Remove Program Properties window is displayed.
- 5** Click **Install**.
The Install Program From Floppy Disk or CD-ROM window is displayed.
- 6** Insert the **KX-P8410 Driver & Utility CD-ROM** into CD-ROM drive.
- 7** Click **Next>**.
The Run Installation Program window is displayed.
- 8** Click **Finish**.
Wait until the Panasonic KX-P8410 Utilities Welcome window is displayed.
- 9** Click **Next>**.
The Setup Type window is displayed.
- 10** Click the type of setup, then click **Next>**.
The Select Program Folder window is displayed.

- 11** Click **Next>** .
The Start Copying Files window is displayed.
- 12** Click **Next>** .
After copying files, the Add Printer Wizard window is displayed.
- 13** Click **Next>** .
- 14** Select LPT port by clicking on the check box.
- 15** Click **Next>** .
- 16** Click **Have Disk...** .
The Install From Disk window is displayed.
- 17** Click **Browse...** .
- 18** Click **Cancel** .
The Locate File window is displayed.
- 19** Select CD-ROM drive.
- 20** Open **WinNT40**, **Disk2**, then open **pgdinta.inf** file.
- 21** Click **OK** .
- 22** Click **Next>** .
- 23** Click **Next>** .

24 Click **Next>** .

25 Click **Finish** .
The printer text page prints.

26 Click **Yes** .

- To connect the printer to a SCSI port, the SCSI port needs to be installed. Refer to the Ports tab of the Panasonic KX-P8410 Properties window (☞ P. 83 to 87).

■Using the Printer in a Network Environment

For the server computer:

To share the printer with the client computer, perform the following steps after installing the printer driver.

1 Double click the **My Computer** icon.

2 Double click the **Printer** icon.

3 Select the **Panasonic KX-P8410 printer**.

4 Click **File** menu, then click **Sharing...** .

5 Click **Shared**.

6 Enter the printer name (ex. KX-P8410).
If the shared printer is used through Windows 95, the printer name must not exceed 12 characters.

7 Click **OK** .

For the client computer:

To use the printer connected to the server, perform the following steps after installing the printer driver.

< For Windows NT 4.0 Users >

- 1** Click **Start**, move the pointer to **Settings** and click **Printers**.
- 2** Double click the **Add Printer** icon.
- 3** Select **Network printer server**.
- 4** Click **Next>**.
- 5** Select the **Panasonic KX-P8410 printer** in the **Shared Printer** box.
- 6** Click **OK** and follow the instructions on the screen.
- 7** Click **Finish**.

< For Windows 95 Users >

- 1** Double click the **My Computer** icon.
- 2** Double click the **Printers** icon.
- 3** Double click the **Add Printer** icon.
- 4** Click **Next>**.

- 5** Click **Network printer**, then click **Next>** .
- 6** Click **Browse...** .
- 7** Select the **KX-P8410 printer**.
- 8** Click **OK** .
- 9** Click **Next>** .
If the server does not have the Printer Driver for Windows 95, click **Have Disk...** .
The Printer Drivers for Windows 95 window is displayed.
- 10** Click **Browse...** .
- 11** Insert the **KX-P8410 Driver & Utility CD-ROM** into CD-ROM drive.
- 12** Select the CD-ROM drive.
- 13** Open **Win95, Disk2**, then open **KXP8410.inf** file.
The Printer Drivers for Windows 95 window is displayed.
- 14** Click **OK** .
- 15** Click **OK** .
- 16** Click **Next>** .
- 17** Click **Finish** .

■Removing the Printer Driver

- 1** Click **Start**, move the pointer to **Settings** and click **Printers**.
- 2** Select **Panasonic KX-P8410**.
- 3** Click **File** menu, then click **Delete**.
- 4** Click **Yes**.

Removing the KX-P8410 Software

If you need to remove the KX-P8410 software, perform the following steps.

■For Windows 3.1 users:

- 1** From the **Program Manager** double click the **Panasonic KX-P8410 Utilities** icon.
- 2** Double click the **Uninstall Utilities** icon.
- 3** Click **Yes**.
- 4** Follow the instructions on the screen.

■For Windows 95 / Windows NT 4.0 users:

- 1** Click **Start**, move the pointer to **Programs**, then to **KX-P8410 Utilities**.
- 2** Click **Uninstall**.
- 3** Click **Yes**.
- 4** Follow the instructions on the screen.

Note:

- For removing the Panasonic KX-P8410 icon in the Printer Folder, refer to Help in Windows 95 / Windows NT 4.0.

Installing Panasonic Font Manager

The Panasonic Font Manager is included in the KX-P8410 Driver & Utility CD-ROM.

To install the above application, perform the following steps.

■For Windows 3.1 users:

- 1** Start Windows 3.1.
- 2** Quit all applications.
- 3** Insert the **KX-P8410 Driver & Utility CD-ROM** into your computer CD-ROM drive.
- 4** Click **File** from the **Program Manager**, then click **Run...**.
- 5** Click **Browse** and select your CD-ROM drive from the [Drives:] box.
- 6** Select **Install.exe** in the **Font** directory, and click **OK**.
- 7** Click **OK**.
The installer starts.
- 8** Follow the instructions on the screen to complete the installation.

■ For Windows 95 / Windows NT 4.0 users:

- 1** Start Windows 95 / Windows NT 4.0.
- 2** Quit all applications.
- 3** Insert the **KX-P8410 Driver & Utility CD-ROM** into your computer CD-ROM drive.
- 4** Click **Start** , move the pointer to **Run...**, then click **Run** .
- 5** Click **Browse** and select your CD-ROM drive.
- 6** Select **Install.exe** in the **Fonts** folder, and click **OPEN** .
- 7** Click **OK** .
The installer starts.
- 8** Follow the instructions on the screen to complete the installation.

Note:

- *When you insert CD-ROM into your drive, application installer may start automatically. In this case, quit the Panasonic quick installer and use the application installer.
For information on how to use the applications, refer to their manuals.*

Setting the Color Density

The printer panel provides an interface to adjust the density of the toner applied to the media. This feature compensates for the changes in density that can occur as environmental conditions changes, toner cartridges or the imaging unit age.

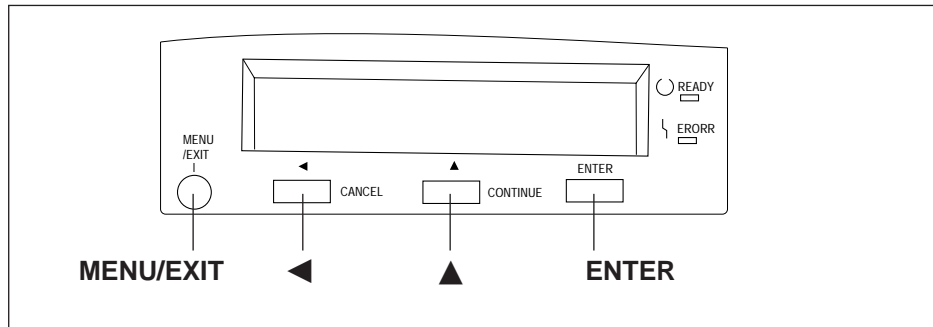

Perform the following steps to adjust the color density:

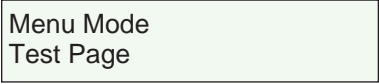
- 1** To print a Color Calibration Page:
 - 1** Press the **MENU/EXIT** button on the printer panel.

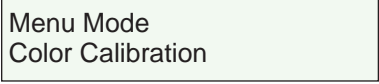
```
Menu Mode
Test Page
```
 - 2** Press the **▲** button.

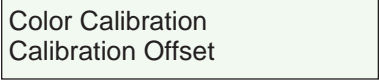
```
Menu Mode
Color Calibration
```
 - 3** Press the **ENTER** button.

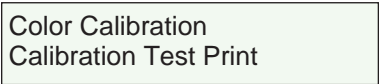
```
Color Calibration
Calibration Offset
```
 - 4** Press the **▲** button 5 times and the following is displayed.

```
Color Calibration
Calibration Test Print
```
 - 5** Press the **ENTER** button.
A Color Calibration Page will be printed.

The current density setting for each color is indicated by the line enclosure on the Color Calibration Page as shown in the following example. The factory default setting for each color density is 0.

Color Calibration Page (Example):

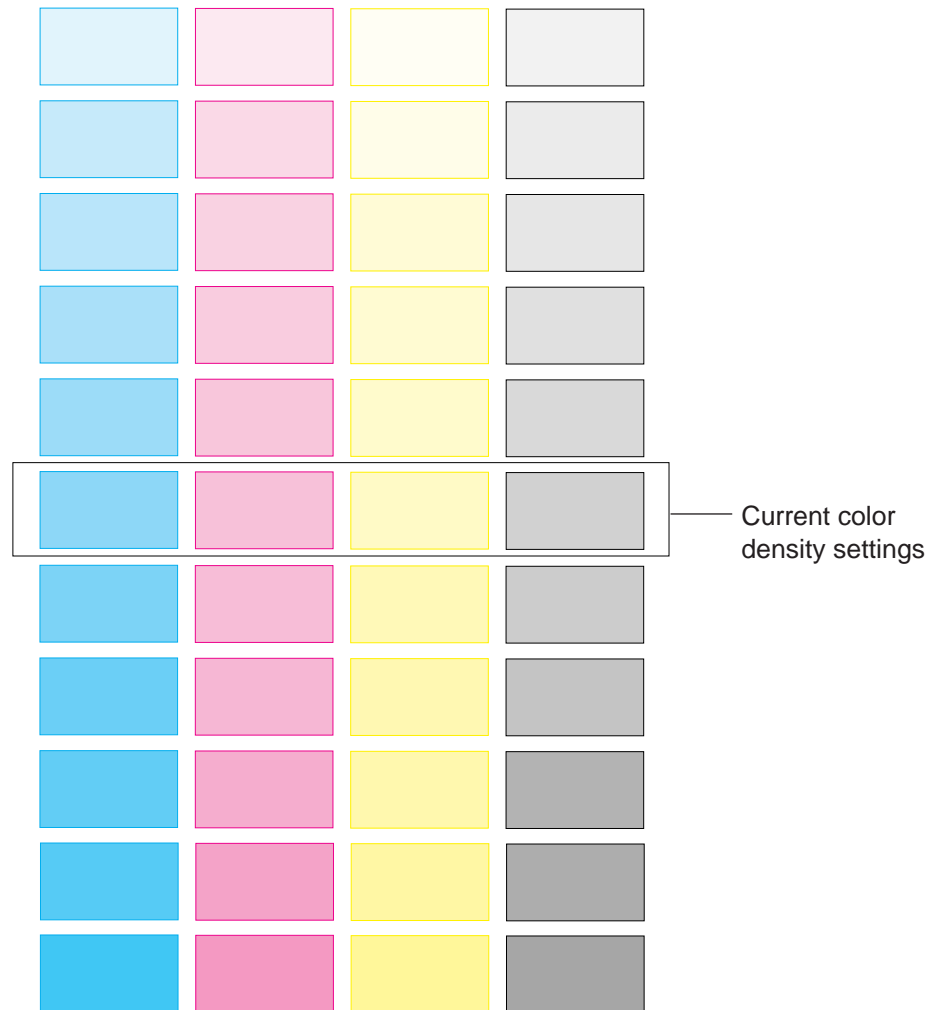

- 2** Compare the current color density settings on the Color Calibration Page with the color density samples on the Color Calibration Card to see if they match.

Place the Color Calibration Page on at least 2 sheets of clean white paper in a well-lighted area.

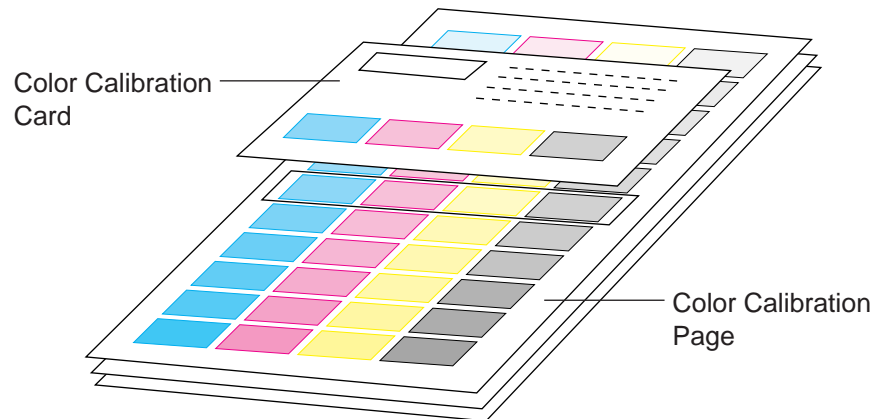

- If they match, then you do not need to adjust the color density and you may proceed with any operation you wish to perform.
 - If they do not match, go to step 3.
- 3** Determine which block on the Color Calibration Page most closely matches the density of the cyan sample on the Color Calibration Card.
 - Repeat step 3 for each color.

4A If you wish to adjust the density for all colors simultaneously, perform the following, then go to step 5.

➊ Repeat instructions ➊ through ➋ of step 1 on [page 54](#).

Color Calibration
Calibration Offset

➋ Press the **ENTER** button.

Calibration Offset
0* (-5 to 5)

➌ Press the ▲/◀ button to darken/lighten all the colors.
Pressing the ▲/◀ button twice selects the next/previous level settings.

(For example:)

- If you wish to make the density setting darker by 2 levels:
— Press the ▲ button 4 times.
- If you wish to make the density setting lighter by 1 level:
— Press the ◀ button 2 times.

➍ Press the **ENTER** button.

Color Calibration
CYAN

➎ Press the ▲ button 4 times and the following is displayed.

Color Calibration
Calibration Test Print

4B If you wish to adjust the density for each color independently, perform the following, then go to step 5.

❶ Repeat instructions ❶ through ❸ of step 1 on [page 54](#).

❷ Press the ▲ button.

```
Color Calibration
CYAN
```

❸ Press the ENTER button.

```
CYAN
0* (-10 to 10)
```

❹ Press the ▲/◀ button to darken/lighten the cyan color.

Pressing the ▲/◀ button twice selects the next/previous level setting.

(For example:)

- If you wish to make the density setting darker by 4 levels:
— Press the ▲ button 8 times.
- If you wish to make the density setting lighter by 2 levels:
— Press the ◀ button 4 times.

❺ Press the ENTER button.

```
Color Calibration
MAGENTA
```

❻ Repeat instructions ❸ through ❺ for each color (MAGENTA, YELLOW, BLACK).

- To skip a color, press the ▲ button.
- To return to a previous color, press the ◀ button.
- Before going to step 5, make sure the following is displayed.

```
Color Calibration
Calibration Test Print
```

5 Press the ENTER button to reprint the Color Calibration Page.

- The line enclosure reflects the changes made to the settings.
- If you are not satisfied with the current color density settings, repeat steps 4 and 5 above.

Notes:

- The color density setting affects the average life of toner.
- Save the Color Calibration Card for future calibrations.

Using the Printer

Menu Mode

The Menu mode includes a Main menu, Item menu, Selection 1 menu and Selection 2 menu which can be changed from the printer panel.

When Ready is displayed in the upper line of the LCD, pressing the MENU/EXIT button will allow you to enter the Menu mode.

Once in the Menu mode:

- Press the ▲/CONTINUE button to:
 - Display the next menu.
 - Display the next item.
 - Increase the numerical value of the selection by 1 or display the next selection.
- Press the ◀/CANCEL button to:
 - Display the previous menu.
 - Display the previous item.
 - Decrease the numerical value of the selection by 1 or display the next selection.
- Press the ENTER button to:
 - Enter a sub - menu.
 - Activate a selection.
 - Print a Configuration/Color Calibration Page.

Before you attempt to change any settings, check the factory default settings in the following table. For details on changing the settings, refer to Outline for Operation (P. 62).

Once you have changed the printer panel settings, they are automatically saved as user default settings even if the power is turned off.

Main Menu	Item Menu	Selection 1 Menu	Selection 2 Menu
Test Page	Configuration Page		
Color Calibration	Calibration Offset	0*1 (-5 to 5)	
	CYAN	0*1 (-10 to 10)	
	MAGENTA	0*1 (-10 to 10)	
	YELLOW	0*1 (-10 to 10)	
	BLACK	0*1 (-10 to 10)	
	Calibration Test Print		
	Reset Calibration	YES NO	
System Setting	Energy Star	ON*1	
		OFF	
	Auto Continue	ON	
		OFF*1	
	Data Timeout	ON	30*1 (30 to 240s)
		OFF*1	
Network *2	IP Address	xxx.xxx.xxx.xxx	
	Subnet Mask	xxx.xxx.xxx.xxx	
	Default Gateway	xxx.xxx.xxx.xxx	

*1 Factory default setting

(continued)

*2 This menu appears when the optional network card is installed.

Using the Printer

Main Menu	Item Menu	Selection 1 Menu	Selection 2 Menu
Maintenance	Page Count	xxxxxx	
	Imaging Unit	Usage=xx%	
	Transfer Unit	Usage=xx%	
	Fuser Unit	Usage=xx%	
	Oil Roll	Usage=xx%	

Outline for Menus

Test Page

Prints general information on printer settings and configuration.

Color Calibration

Adjusts the toner density for each color independently or all the colors.

■ Calibration Offset

Adjusts the density for all the colors (CYAN, MAGENTA, YELLOW and BLACK). Setting a higher number provides darker colors and setting a lower number provides lighter colors.

■ CYAN / MAGENTA / YELLOW / BLACK

Adjusts the density for each color independently. Setting a higher number provides darker color and setting a lower number provides lighter color.

■ Calibration Test Print

Prints a Color Calibration Page with the current density settings.

■ Reset Calibration

Setting YES resets the current settings back to the default settings.

Note:

- *The color density setting affects the average life of toner.*

System Setting

Configures the printer.

■ Energy Star

If Energy Star is enabled, the printer enters the Energy Star mode when the printer is idle for 30 minutes.

■ Auto Continue

With the Auto Continue set to ON, the printer automatically recovers from the following error conditions if no recovery operation is done for 10 seconds.

- Memory Overflow
- SCSI communication error

■ Data Timeout

With the Data Timeout set to ON, the printer automatically returns to Ready status if the printer does not receive any data from a computer within the time period set in this selection (30 to 240 seconds).

Network

Sets the addresses used in TCP / IP Protocol. During setting, use the ◀/CANCEL button to move the cursor and the ▲/CONTINUE button to increase the numerical value.

Maintenance

Displays the page count of the printer and the consumption of supplies. It also gives you an idea when the following supplies need to be replaced. The following table shows the average life of each supply, which is based on a 5% image area and standard density. Refer to [pages 103](#) and [104](#) for details.

Supplies	Average life
Imaging Unit *	60,000 images
Transfer Unit	80,000 pages
Fuser Unit *	31,000 pages
Oil Supply Roll *	15,500 pages

* When a supply is replaced with a new one, the printer will automatically reset the page counter for that supply to 0.

Using the Printer

Outline for Operation

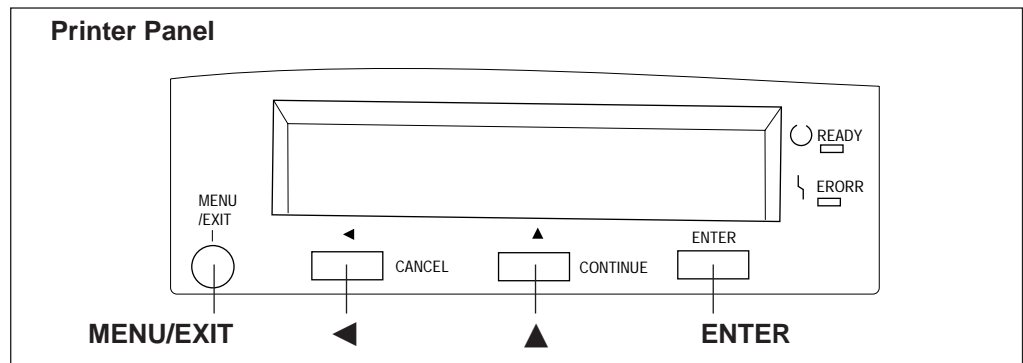

- 1** Press the **MENU/EXIT** button to enter the Menu mode.
- 2** Press the **▲/◀** button until the desired menu is displayed.
- 3** Press the **ENTER** button to enter the item menu.
- 4** Press the **▲/◀** button until the desired item is displayed.
- 5** Press the **ENTER** button to enter the Selection 1 menu.
 - If you have selected Configuration Page or Calibration Test Print in step 4, the printer will exit the Menu mode after printing the page.
- 6** Press the **▲/◀** button to increase/decrease the numerical value or display the desired selection.
- 7** Press the **ENTER** button to activate your selection and advance to the next item for the same menu that you selected in step 2.
 - If you have selected Data Timeout in step 4, you will enter the Selection 2 menu. Press the **▲/◀** button to increase/decrease the data time out, then press the Enter button to activate your selection and exit the Menu mode.
- 8** If you wish to set more items in the same menu, repeat steps 4 to 7 above.
 - To exit the Menu mode at any stage, press the MENU/EXIT button.
 - To change the setting of an item of a different menu, first exit the Menu mode, then repeat steps 1 to 8 above.

Displaying the Panasonic KX-P8410 Window (for Windows 95 / 3.1)

The KX-P8410 window can be displayed from **Windows** (☞ below) or from an **application** (☞ P. 65).

Note:

- Available option tabs and operation buttons displayed through Windows 95 are different from those displayed through Windows 3.1.

A Choosing Printer Properties Under Windows:

■ For Windows 95

- 1** Click **Start**, select **Settings**, then click **Printers**.
The **Printers** window is displayed.
- 2** Click the **Panasonic KX-P8410** printer icon.
- 3** Click the **File** menu, then click **Properties**.
The **Panasonic KX-P8410 Properties** window is displayed.

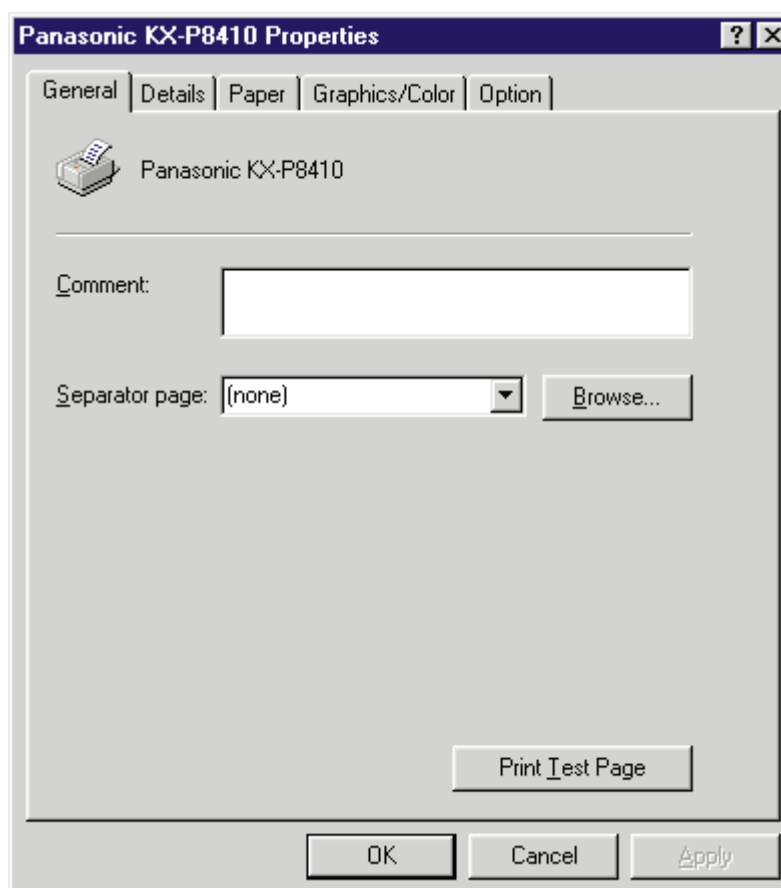

Using the Printer

4 Click a tab to view the features.

Details Tab ([↔ P. 66](#))

Paper Tab ([↔ P. 67](#))

Graphics/Color Tab ([↔ P. 69](#))

Option Tab ([↔ P. 72](#))

■ For Windows 3.1

1 Double-click **Main** icon and **Control Panel** icon, then double-click **Printers** icon.

The **Printers** window is displayed.

2 Select **Panasonic KX-P8410 on LPT1***, then click **Setup**.

The **Panasonic KX-P8410** window is displayed.

* The port name (LPT1) may vary depending on the connection of your printer.

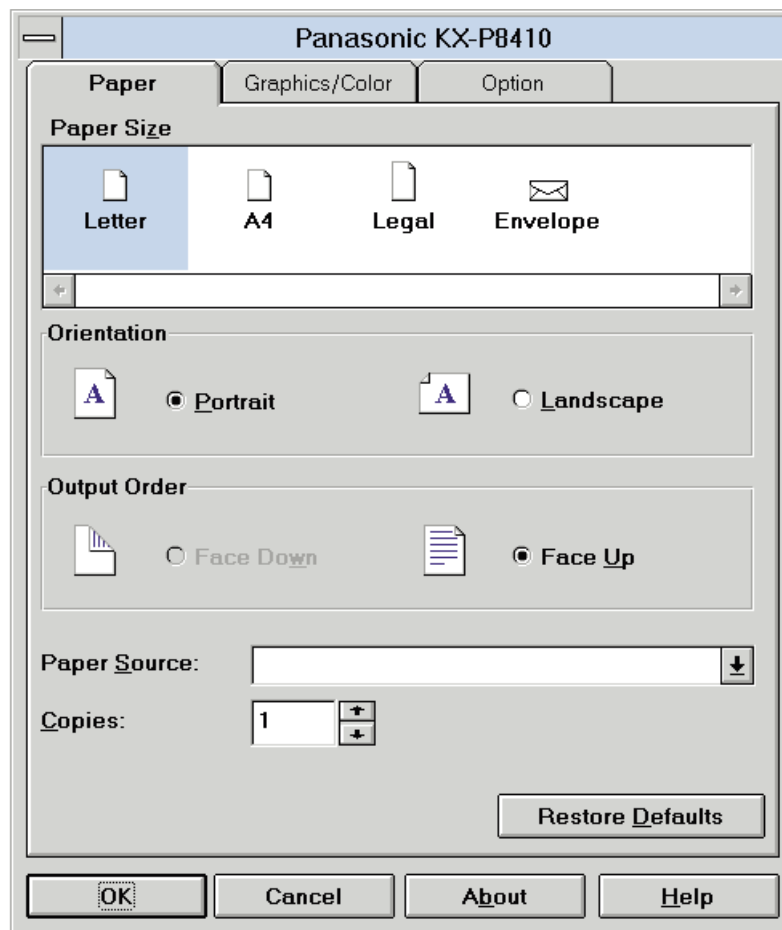

3 Click a tab to view the features.

Paper Tab ([↔ P. 67](#))

Graphics/Color Tab ([↔ P. 69](#))

Option Tab ([↔ P. 72](#))

B From an application

For example, to print a document created in Microsoft WordPad on Windows 95, perform the following steps.

- 1** Click **Start**, select **Programs**, select **Accessories**, then click **WordPad**.

The **WordPad** window is displayed.

- 2** Click the **File** menu, then click **Print...**

The **Print** window is displayed.

- 3** Select Panasonic KX-P8410 in the Name : box.

- 4** Click **Properties**.

The **Panasonic KX-P8410** window is displayed.

- 5** Click a tab to view the features.

Paper Tab (↔ P. 67)

Graphics/Color Tab (↔ P. 69)

Option Tab (↔ P. 72)

Note:

- *The print options in the File menu depend on the Windows application. Refer to the application manual.*

The instructions described hereafter are based on the windows displayed in Windows 95. However, most instructions for Windows 3.1 are the same as for Windows 95.

Using the Printer

Details Tab

Note:

- This option is available only for Windows 95.

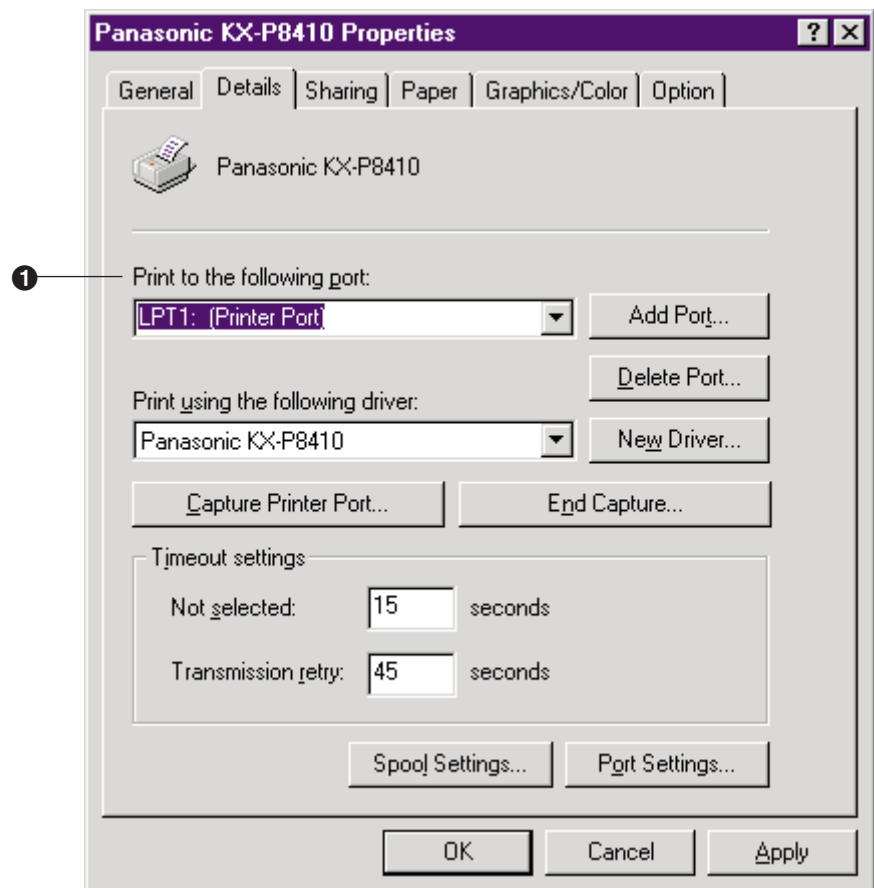

1 Print to the following port

Select the port where the parallel interface cable is connected. When you are using the SCSI interface cable, select the KX-P8410GDI (KX-P8410 on SCSI).

For the functions of other buttons, refer to the Help menu in the Windows.

Paper Tab

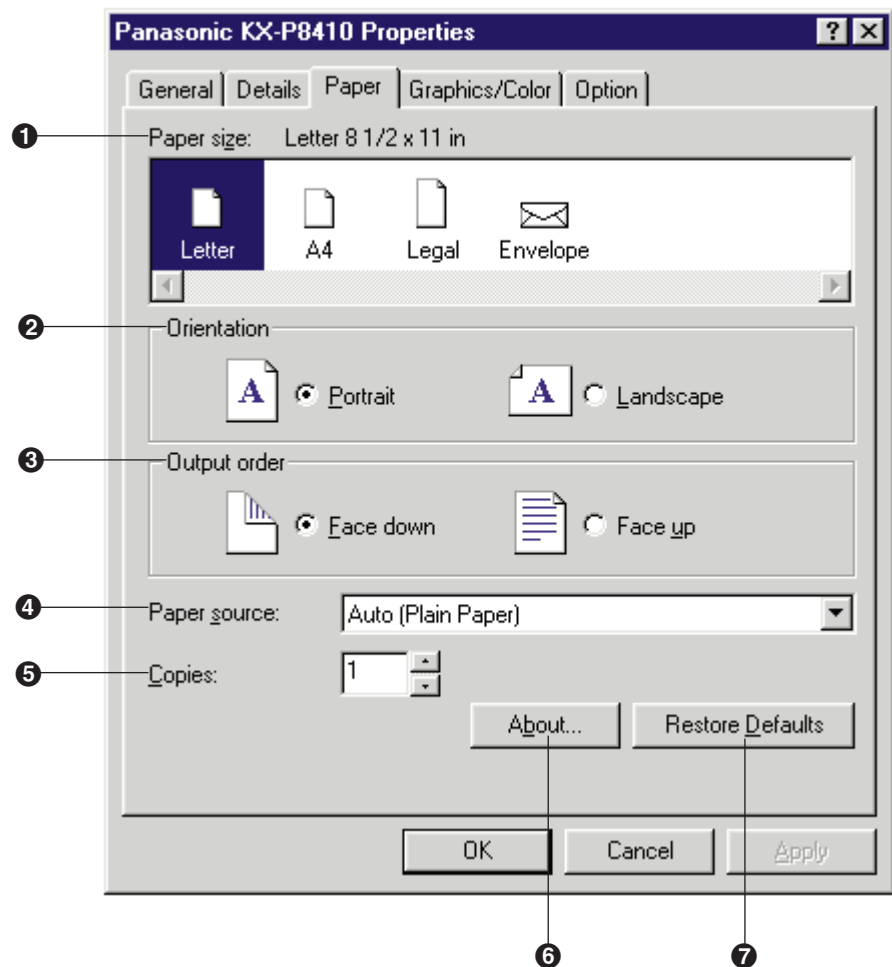

❶ Paper size

Selects a different paper size.
Letter, A4, Legal or Envelope can be selected.

❷ Orientation

Selects Portrait (vertical) or Landscape (horizontal).

Portrait



Landscape



❸ Output order

Specifies whether the document prints face up or face down in the output tray. This selection is not effective when the multi-purpose tray (MPT Plain Paper, MPT Transparency, etc.) is selected in the **Paper source** (P. 68). When the multi-purpose tray is selected, **Face up** is selected automatically.

Using the Printer

④ Paper source

Selects media by choosing the location (trays) or the type of media.

- **Auto [Plain Paper]:**

Prints on paper loaded in a paper tray. The printer picks paper from the paper tray that loaded with the media size you selected in an application software. When the tray is empty, the printer automatically picks from another paper tray of the same media size in the order of **Upper, Middle** and **Lower**.

- **Auto [Transparency]:**

Prints on transparency loaded in a transparency tray. The printer picks transparency from the transparency tray that loaded with the media size you selected in an application software. When the tray is empty, the printer automatically picks from another transparency tray of the same media size in the order of **Upper, Middle** and **Lower**.

- **Upper :**

Prints on media loaded in the standard tray.

- **Middle* :**

Prints on media loaded in the upper tray (optional feeder).

- **Lower* :**

Prints on media loaded in the lower tray (optional feeder).

- **MPT Plain Paper, MPT Transparency, MPT Label, MPT Coated Paper, MPT Envelope, MPT Paper 2nd Side :**

Prints on paper, transparency or label , etc. loaded in the Multi-purpose tray. The printer will print on the selected media with optimal quality.

* If the optional feeder has not been installed, the printer selects the standard tray automatically.

⑤ Copies

Determines how many copies of the document will be printed.

Note:

- *The number of copies can be also determined using some application softwares. However, it is recommended to set the number of copies using one method, either from this driver or from an application software to avoid having a printing problem.*

⑥ About... button

Displays the window which contains the program version and copyright information.

⑦ Restore Defaults button

Resets the **Paper** tab's settings to the default settings.

Graphics / Color Tab

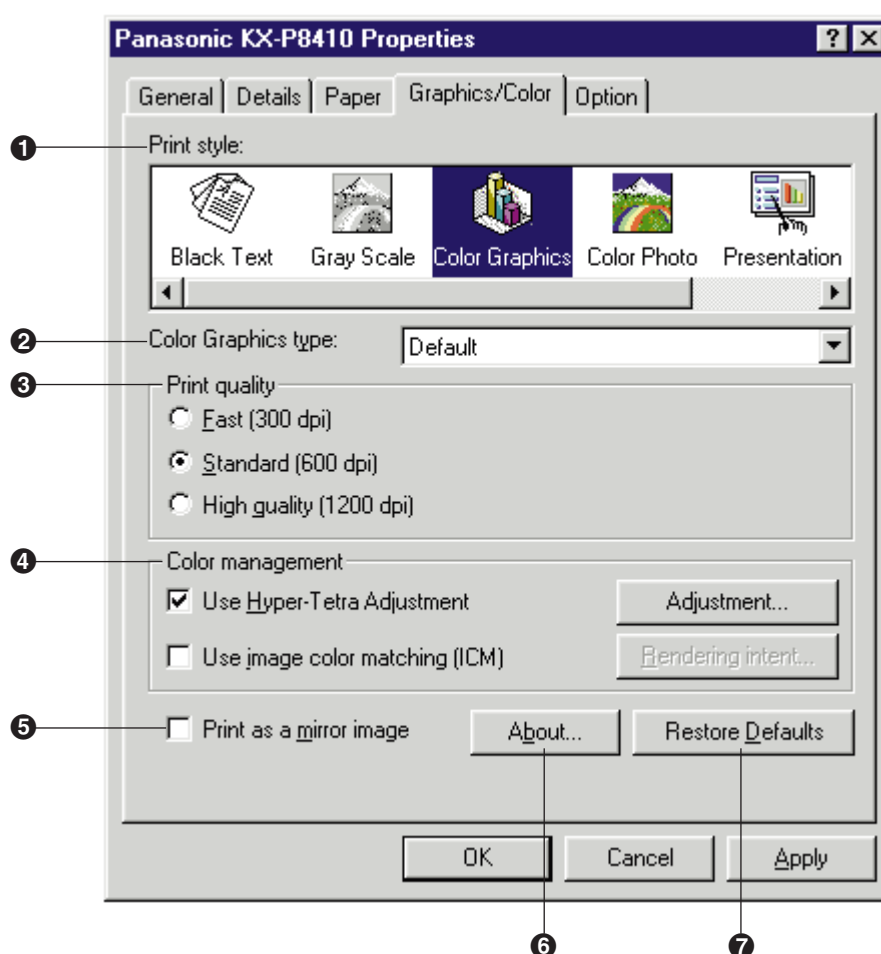

1 Print style

Select a type which is the closest to your document to print for optimal quality.

• Black Text:

Prints the document in black and white the quickest. Select this for black and white text files.

• Gray Scale:

Prints the document in black and white. Select this for monochrome halftone images.

• Color Graphics: (default)

Prints the document in color. Select this for computer graphics, colored text, and spreadsheets with color graphics. Small text can be printed more clearly than when printed in Presentation.

• Color Photo:

Prints the document in color. Select this for photos or images from a photo CD.

• Presentation:

Prints the document in color. Select this for presentation copies. Presentation provides a clearer tone than Color Graphics.

Using the Printer

② Color Graphics type

Color Graphics is a print style that simulates shades of color by changing the dot patterns. You can select a dot pattern from **Default***¹, **Dither A**, or **Dither B**.

This selection is effective only when **Color Graphics** is selected.

*¹ Dither A or B will be automatically selected according to a print quality you have selected.



Dither A



Dither B

③ Print quality

Selects a print quality. **Fast** (300 dpi), **Standard** (600 dpi) or **High quality** (1200 dpi) can be selected. When the **Gray Scale** or **Color Photo** print style is selected, the **High quality (1200 dpi)** cannot be selected. A higher resolution provides better print quality. However, the throughput will be diminished.

When **Presentation** is selected in the **Print style**, print quality cannot be selected and 300 dpi is automatically assigned.

④ Color management

This feature provides two-color adjustment functions as described below when printing a document with **Color Graphics**, **Color Photo** or **Presentation** print style.

● Use Hyper-Tetra Adjustment

Adjusts the brightness, contrast, hue, saturation, or red, green, blue of the image. For the adjustment, refer to **Using the Hyper-Tetra Adjustment** ( P. 93).

● Use image color matching (ICM)*¹

The printer assigns the best color possible to accurately represent the original color by selecting different rendering intents (Saturation, Contrast or Colormetric). Click on this check box, then click the Rendering intent box. The Rendering intent window appears. Select the desired rendering intent, which determines how the printer assigns the color.

*¹ This option is available only for Windows 95.

⑤ Print as a mirror image

Clicking on this check box allows you to print a mirror image of the document.

⑥ About button

Displays the window that contains the program version and copyright information.

⑦ Restore Defaults button

Resets the **Graphics / Color** tab's settings to the default settings.

Option Tab

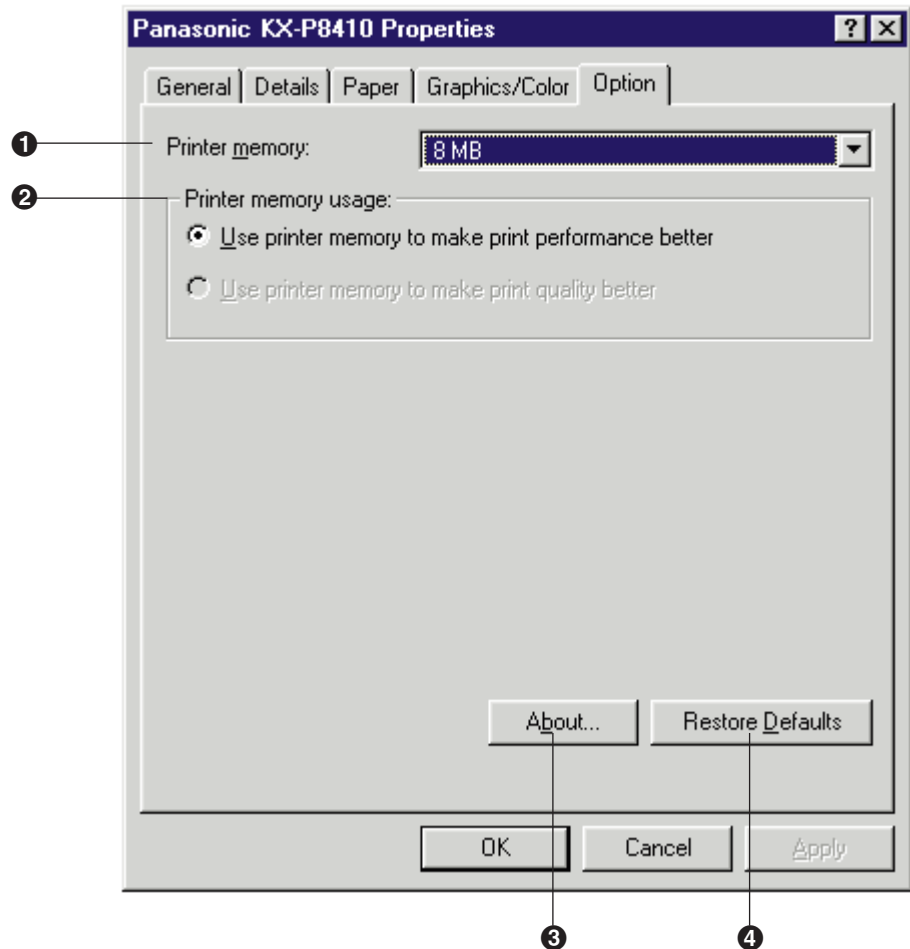

1 Printer memory

Selects the amount of memory installed in the printer. If the amount of memory in the printer does not match this setting, a **MEMORY OVERFLOW** message might be displayed. To determine how much memory is installed in the printer, print out the Test page ([P. 39](#)).

As the printer memory increases, printing throughput improves. If the total amount of memory installed in the printer is more than 32 MB, **Use printer memory to make print quality better** can be selected in the **Printer memory usage** box.

② Printer memory usage

Determines how the printer memory is used, either for better print performance or for better print quality. This selection is effective only when the **Gray Scale** or the **Color Photo** print style is selected and the **Standard (600 dpi)** is selected.

- **Use printer memory to make print performance better**

Sends the data to the printer with the standard level of compression to improve throughput.

- **Use printer memory to make print quality better**

Sends the data to the printer with the lower level of compression or without compression to improve the print quality. However, the throughput will be diminished. More than 32 MB is required on the printer to select this option.

③ About button

Displays the window that contains the program version and copyright information.

④ Restore Defaults button

Resets the **Option** tab's setting to the default setting.

Using the Printer

Displaying the Panasonic KX-P8410 Default Document Properties Window (for Windows NT 4.0)

The KX-P8410 Default Document Properties window can be displayed from **Printers under Windows** (☞ see A below) or from **an application** (☞ see B on page 75).

A From Printers Under Windows NT 4.0

- 1 Click **Start**, select **Settings**, then click **Printers**.
The **Printers** window is displayed.
- 2 Click the **Panasonic KX-P8410** icon.
- 3 Click the **File** menu, then click **Document Defaults....**
The **Panasonic KX-P8410 Default Document Properties** window appears.

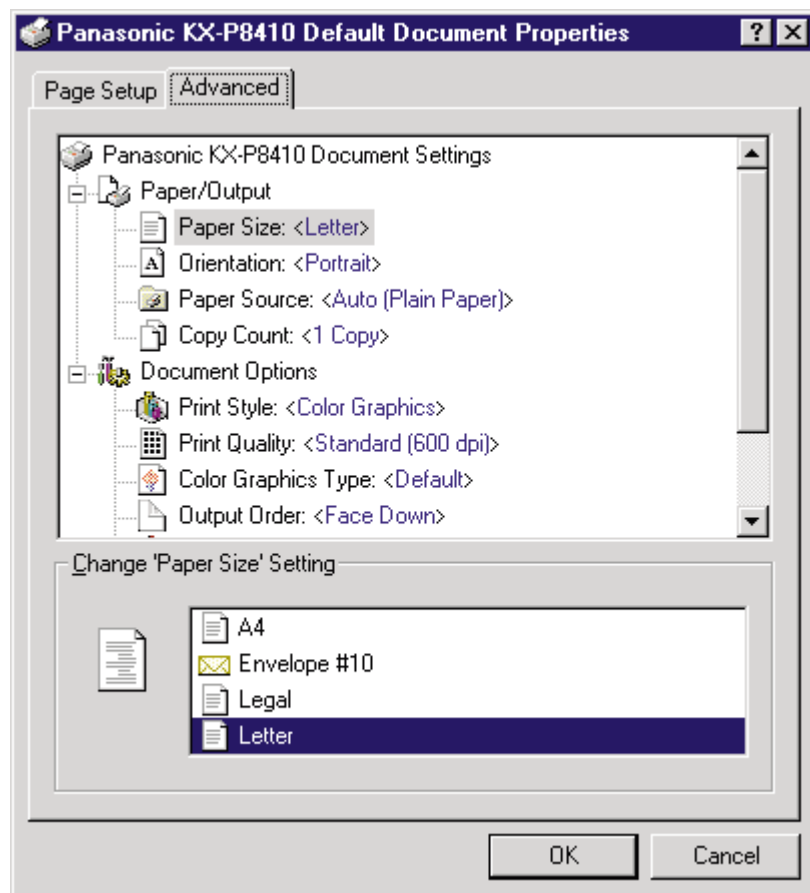

4 Click a tab to view the features.

Page Setup Tab ( P. 76)

Advanced Tab ( P. 78)

B From an application

For example, to print a document created in Microsoft WordPad on Windows NT 4.0, perform the following steps.

1 Click **Start**, select **Programs**, select **Accessories**, then click **WordPad**.

The **WordPad** window is displayed.

2 Click the **File** menu, then click **Print... .**

The **Print** window is displayed.

3 Click **Properties**.

The **Panasonic KX-P8410 Document Properties** window is displayed.

4 Click a tab to view the features.

Page Setup Tab ( P. 76)

Advanced Tab ( P. 78)

Note:

- The print options in the File menu depend upon the Windows application. Refer to the application manual.

Using the Printer

Page Setup Tab

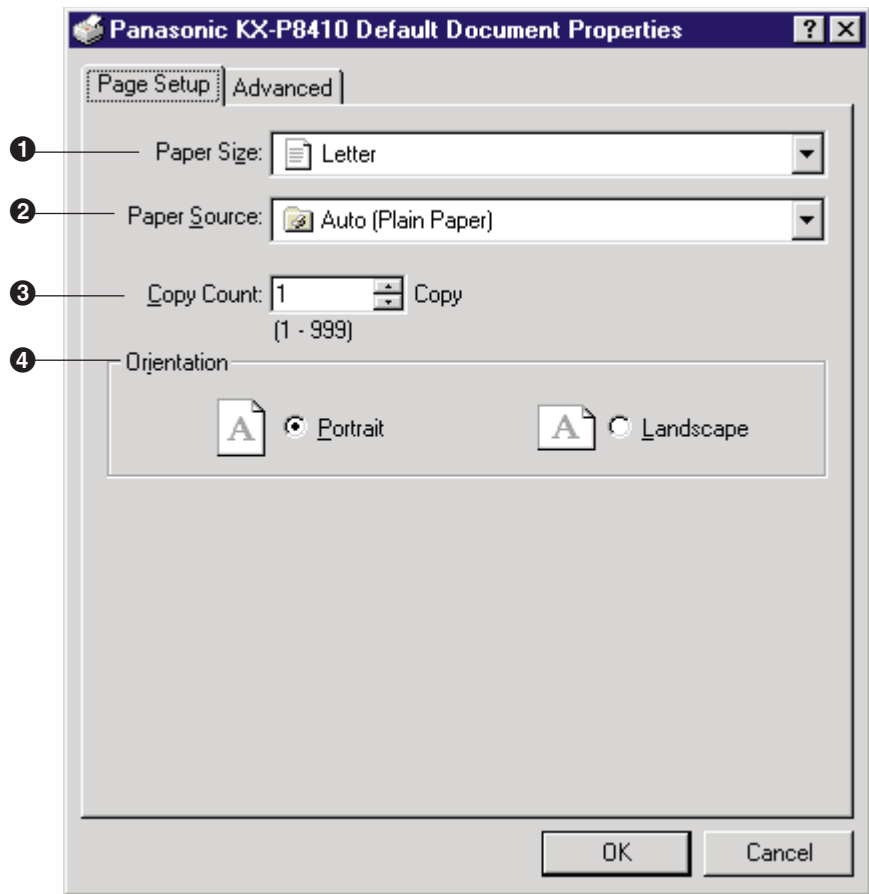

1 Paper Size

Selects a different paper size.

Letter, A4, Legal or Envelope #10 can be selected.

② Paper Source

Selects media by choosing the location (trays) or the type of media.

- **Auto [Plain Paper]:**
Prints on paper loaded in a paper tray. The printer picks paper from the paper tray that is loaded with the media size you selected in the application software. When the tray is empty, the printer automatically picks from another paper tray of the same media size in the order of **Upper, Middle** and **Lower**.
- **Auto [Transparency]:**
Prints on transparency loaded in a transparency tray. The printer picks transparency from the transparency tray that is loaded with the media size you selected in the application software. When the tray is empty, the printer automatically picks from another transparency tray of the same media size in the order of **Upper, Middle** and **Lower**.
- **Upper :**
Prints on media loaded in the standard tray.
- **Middle*¹ :**
Prints on media loaded in the upper tray (optional feeder).
- **Lower*¹ :**
Prints on media loaded in the lower tray (optional feeder).
- **MPT Plain Paper, MPT Transparency, MPT Label, MPT Coated Paper, MPT Envelope, MPT Paper 2nd Side :**
Prints on paper, transparency or label, etc. loaded in the Multi-purpose tray. The printer will print on the selected media with optimal quality.

*¹ If the optional feeder has not been installed, the printer selects the standard tray automatically.

③ Copy Count

Determines how many copies of the document will be printed.

Note:

- *The number of copies can also be determined using the application software. However, it is recommended to set the number of copies using one method, either from this driver or from the application software to avoid printing problems.*

④ Orientation

Selects Portrait (vertical) or Landscape (horizontal).

Portrait



Landscape



Using the Printer

Advanced Tab

Two categories (Paper/Output and Document Options) for document settings are available. To display the items of a category, click on that category.

■ Paper/Output

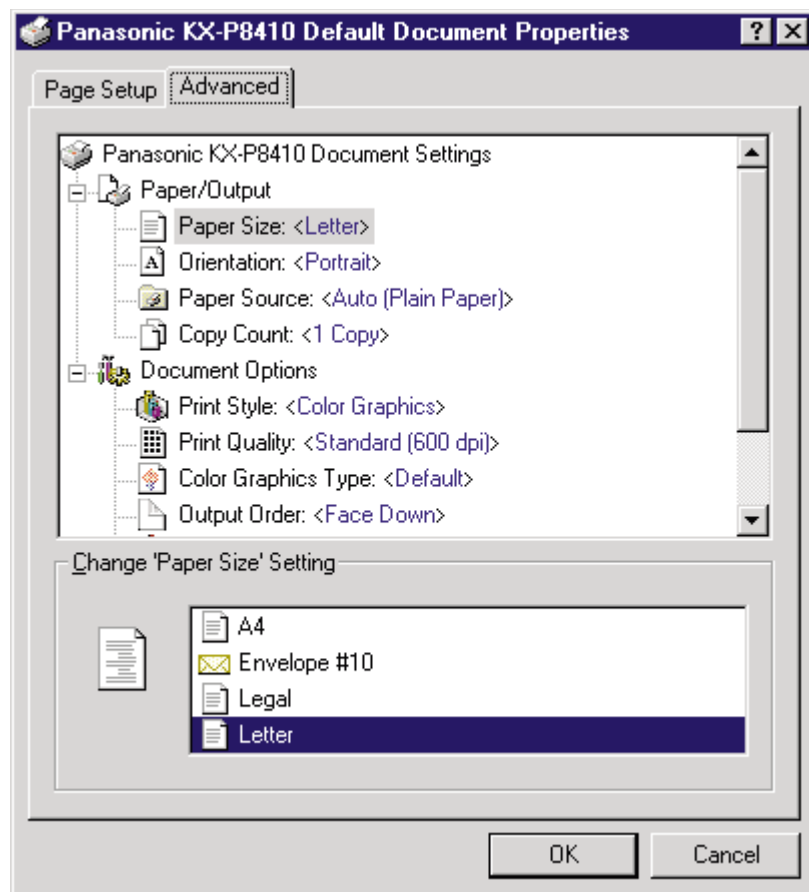

As for the features of each items (Paper Size, Orientation, Paper Source, Copy Count), refer to **Page Setup Tab** (☞ P. 76).

Clicking on an item displays its selections in the **lower box**. Click your desired selection, then click **OK**.

■ Document Options

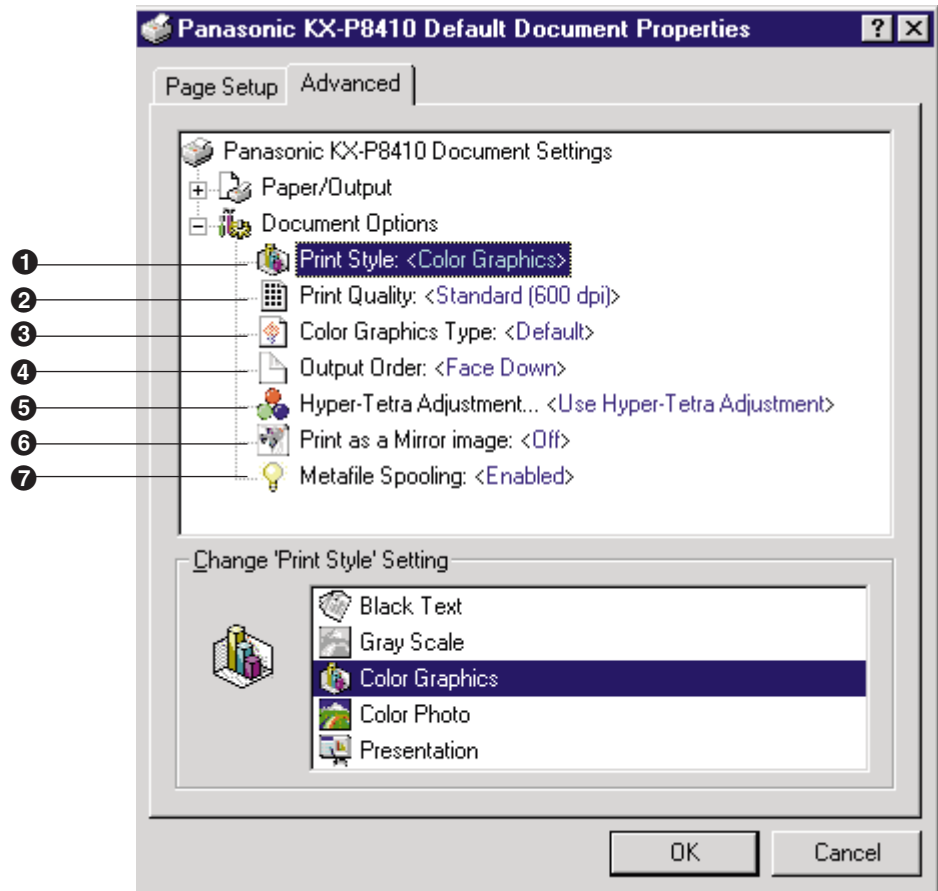

① Print Style

Click on **Print Style** to display its selections in the **lower box**, and select a type which is the closest to your document to ensure optimal print quality.

- **Black Text:**

Prints the document in black and white. Select this for black and white text. This is the fastest printing option.

- **Gray Scale:**

Prints the document in black and white. Select this for monochrome halftone images.

- **Color Graphics: (default)**

Prints the document in color. Select this for computer graphics, color text, spreadsheets with color graphics.
(Small text can be printed more clearly than when printed in presentation.)

- **Color Photo:**

Prints the document in color. Select this for photo images such as a photo from a CD.

- **Presentation:**

Prints the document in color. Select this for presentation copies.
(Presentation provides a clearer tone than Color Graphics.)

Using the Printer

② Print Quality

Click on **Print Quality** to display its selections in the **lower box**, and select a print quality. **Fast** (300 dpi), **Standard** (600 dpi) or **High quality** (1200 dpi) can be selected. When the **Gray Scale** or **Color Photo** print style is selected, the **High quality (1200 dpi)** cannot be selected. A higher resolution provides better print quality. However, the throughput speed is diminished.

When **Presentation** is selected in the **Print style**, print quality cannot be selected and 300 dpi is automatically assigned.

③ Color Graphics Type

Color Graphics is a print style that simulates shades of color by changing the dot patterns. You can select a dot pattern from **Default***¹, **Dither A**, or **Dither B**.

This selection is effective only when **Color Graphics** is selected.

*¹ Dither A or B will be automatically selected according to the print quality you have selected.



Dither A



Dither B

④ Output Order

Specifies whether the document exits face up or face down into the output tray. This selection is not effective when the multi-purpose tray (MPT Plain Paper, MPT Transparency, etc.) is selected in the **Paper Source** (👉 P. 77). When the multi-purpose tray is selected, **Face up** is selected automatically.

⑤ Hyper-Tetra Adjustment...

Adjusts the brightness, contrast, hue, saturation, or red, green, blue of the image. For the adjustment, refer to **Using the Hyper-Tetra Adjustment** (👉 P. 93).

⑥ Print as a Mirror image

Clicking on **Print as a Mirror image** allows you to print a mirror image of the document.

⑦ Metafile Spooling

Specifies the format in which the printing information is stored on your disk for printing. Generally, metafile spooling set to **Enabled** frees up your program faster than **Disabled**.

Using the Printer

■ When Panasonic KX-P8410 Document Settings is selected

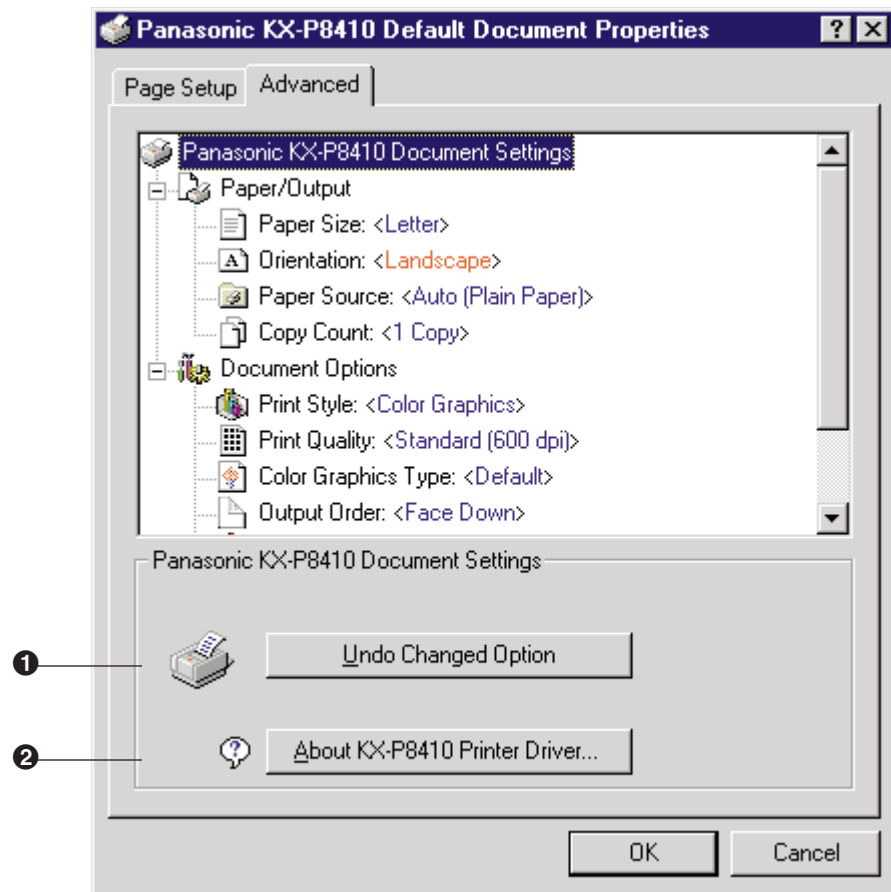

① Undo Changed Option

Returns the **Page Setup** and **Advanced** tab's settings to the previous settings.

② About KX-P8410 Printer Driver...

Displays the window that contains the program version and copyright information.

Displaying the Panasonic KX-P8410 Properties Window (for Windows NT 4.0)

- 1** Click **Start**, select **Settings**, then click **Printers**.
The **Printers** window is displayed.
- 2** Click the **Panasonic KX-P8410** icon.
- 3** Click the **File** menu, then click **Properties**.
The **Panasonic KX-P8410 Properties** window is displayed.

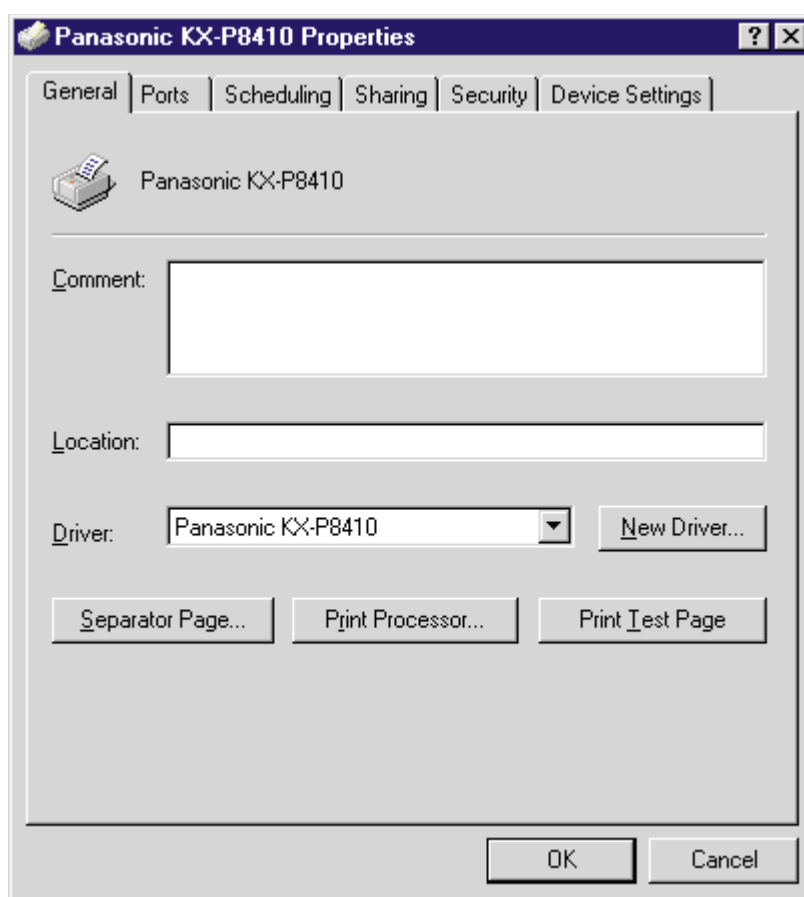

- 4** Click a tab to view the features.
 - Ports Tab** (☞ P. 84)
 - Sharing Tab** (☞ P. 88)
 - Device Settings Tab** (☞ P. 91)

For the features of the other tabs, refer to the Help menu in the Windows NT 4.0.

Using the Printer

Ports Tab (SCSI port)

Note:

- This option is available only for Windows NT 4.0.

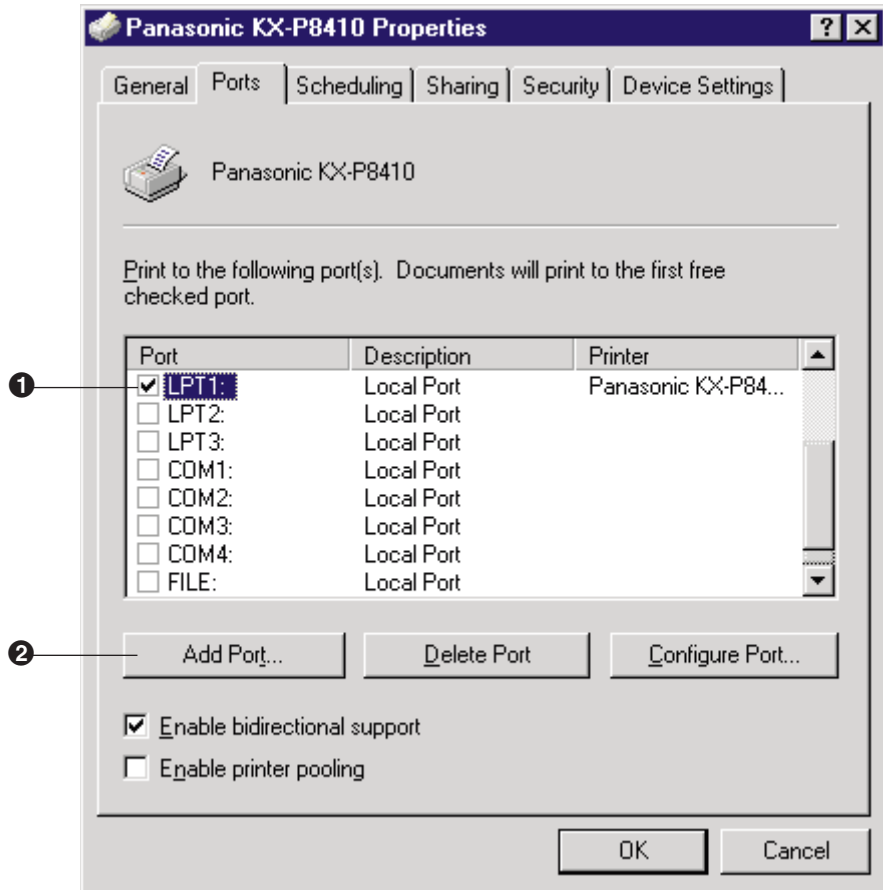

1 Checked port

Documents will print to the checked port.

2 Add Port... button

Adds a new port ([P. 85 Installing the SCSI port](#))

■ Installing the SCSI port

Notes:

- When printing through the SCSI port, the access speed between other connected SCSI devices get slower.
- To connect the KX-P8410 to your SCSI port, a SCSI driver and ASPI Manager need to be installed. Refer to your SCSI board manual.

1 Click **Add Port...** .

The **Printer Ports** window appears.

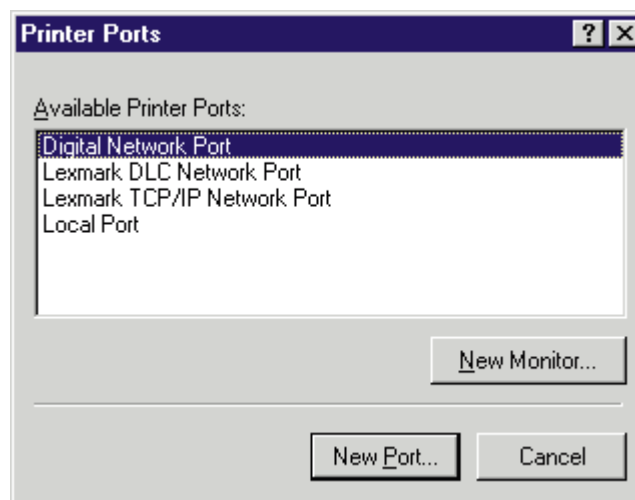

2 Click **New Monitor...** .

The **Installing Print Monitor** window appears.

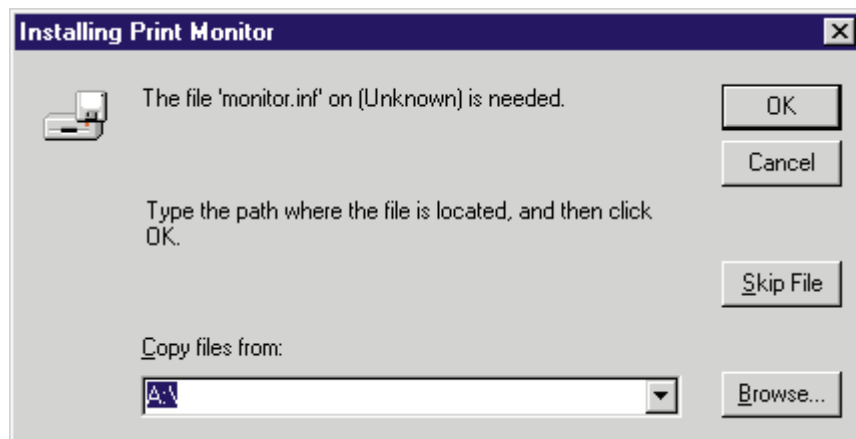

Using the Printer

3 Click **Browse...** .

4 Click **Cancel** .

The **Locate File** window is displayed.

Note:

- The SCSI port cannot be installed through the **Monitor.inf** file copied to a directory with long file name.

5 Insert the **KX-P8410 Driver & Utility CD-ROM** into the CD-ROM drive.

6 Select CD-ROM drive.

7 Open **WinNT40, Disk2** then open **Monitor.inf** file.

8 Click **OK** .

The **Printer Ports** window is displayed.

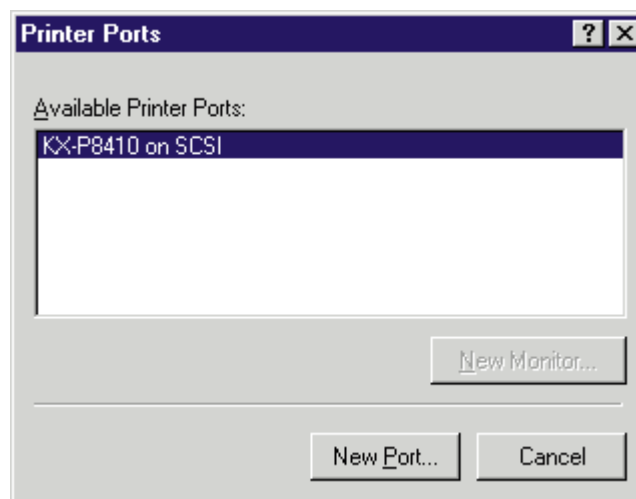

9 Click **New Port...** .

The **Port Name** window is displayed.

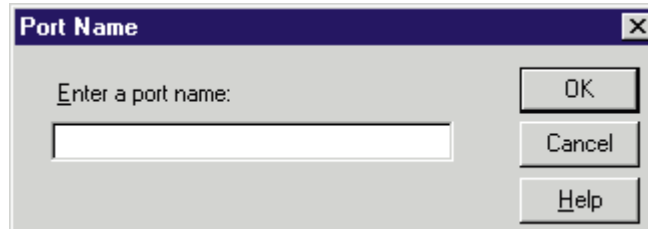

10 Type the port name (for example; KXP8410GDI), then click **OK** .

The **Printer Ports** window is displayed.

11 Click **Close** .

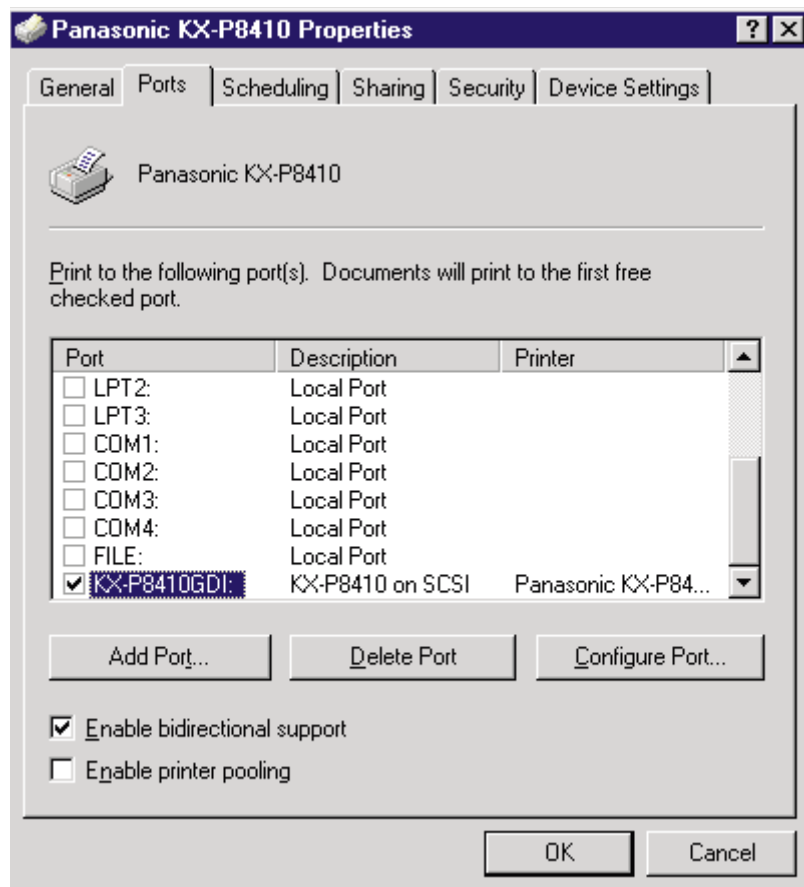

Sharing Tab

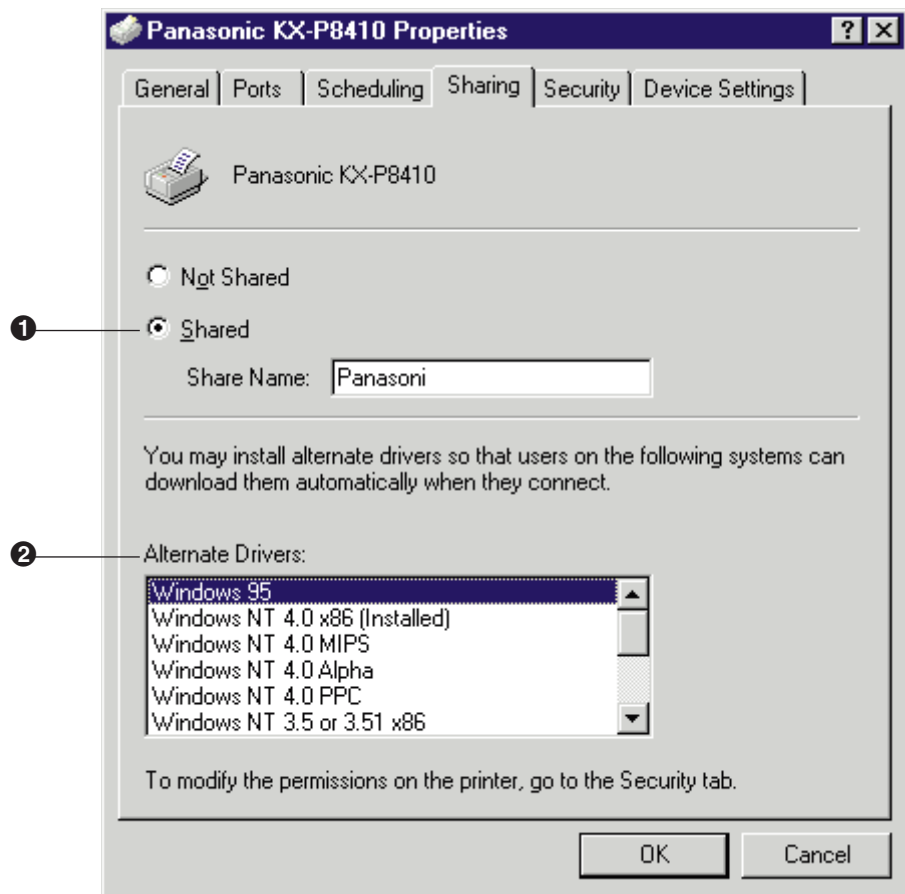

1 Shared

To share the printer over the network.

For the setup operation, refer to **Sharing the printer with a client computer** (P. 89).

2 Alternate Drivers

To install an alternate driver.

For the installation, refer to **Installing an alternate driver** (P. 89).

■ Sharing the printer with a client computer

1 Click **Shared**.

2 Type the printer name (for example: KX-P8410).

Note:

- If the shared printer is used through Windows 95, the printer name must not exceed 12 characters.

3 Click **OK**.

■ Installing an alternate driver (for example: Windows 95)

1 Select **Windows 95**, then click **OK**.

The **Insert Disk** window is displayed.

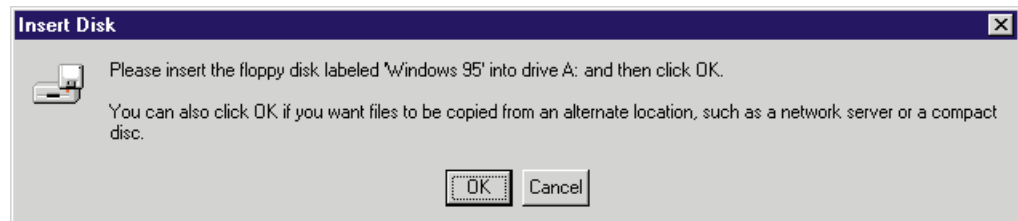

2 Click **OK**.

The **Printer Drivers for Windows 95** window is displayed.

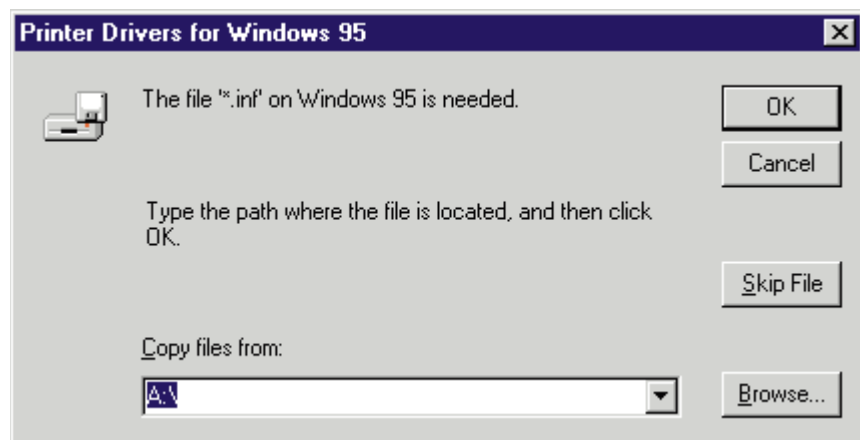

3 Click **Browse...**.

Using the Printer

4 Click **Cancel** .

The **Locate File** window is displayed.

5 Insert the supplied **KX-P8410 Driver & Utility CD-ROM** into the CD-ROM drive.

6 Select CD-ROM drive.

7 Open **Win95, Disk2**, then open **KXP8410.inf** file.

The **Printer Drivers for Window 95** window is displayed.

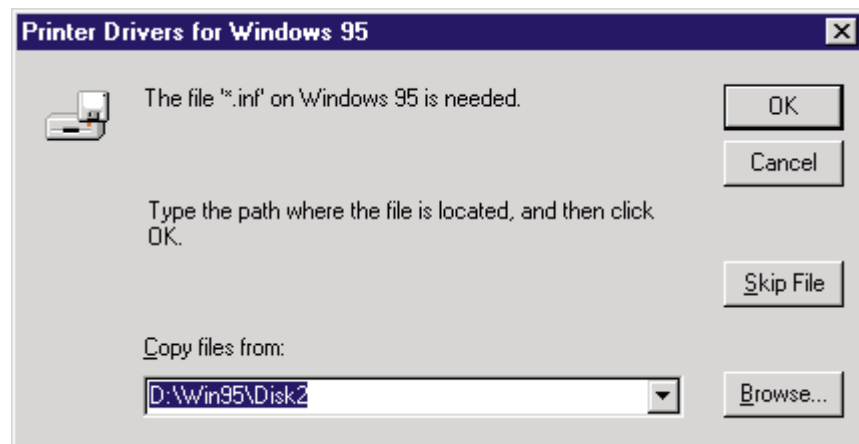

8 Click **OK** .

Device Settings Tab

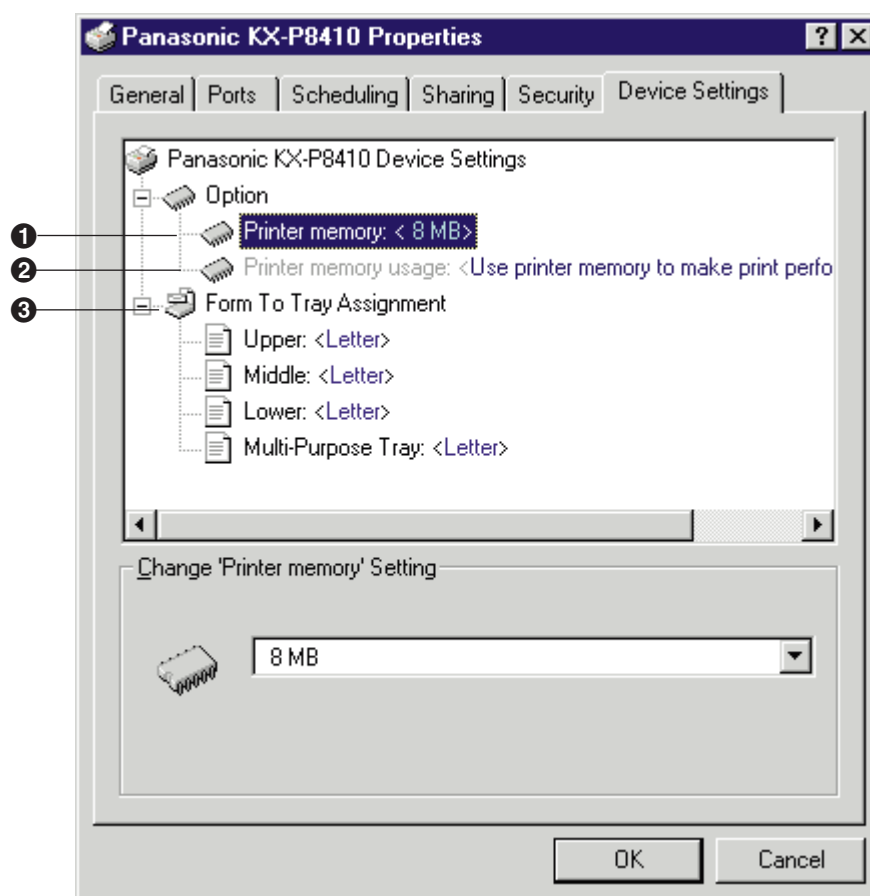

1 Printer memory

Selects the amount of memory installed in the printer. If the amount of memory in the printer does not match this setting, a **MEMORY OVERFLOW** message might be displayed. To determine how much memory is installed in the printer, print out the Test page (P. 39). As the printer memory increases, printing throughput improves. If the total amount of memory installed in the printer is more than 32 MB, **Printer memory usage** option (2) becomes effective.

Using the Printer

② Printer memory usage

Determines how the printer memory is used, either for better print performance or for better print quality. This selection is effective only when the **Gray Scale** or the **Color Photo** print style is selected and the **Standard (600 dpi)** is selected.

More than 32 MB is required on the printer to select this option.

• Use printer memory to make print performance better

Sends the data to the printer with the standard level of compression to improve throughput.

• Use printer memory to make print quality better

Sends the data to the printer with a lower level of compression or without compression to improve the print quality. However, the throughput will be diminished.

③ Form To Tray Assignment

Server can assign and display the media loaded in the printer. Client can view the media assignment. This assignment does not affect any print job.

■ When Panasonic KX-P8410 Device Settings is selected

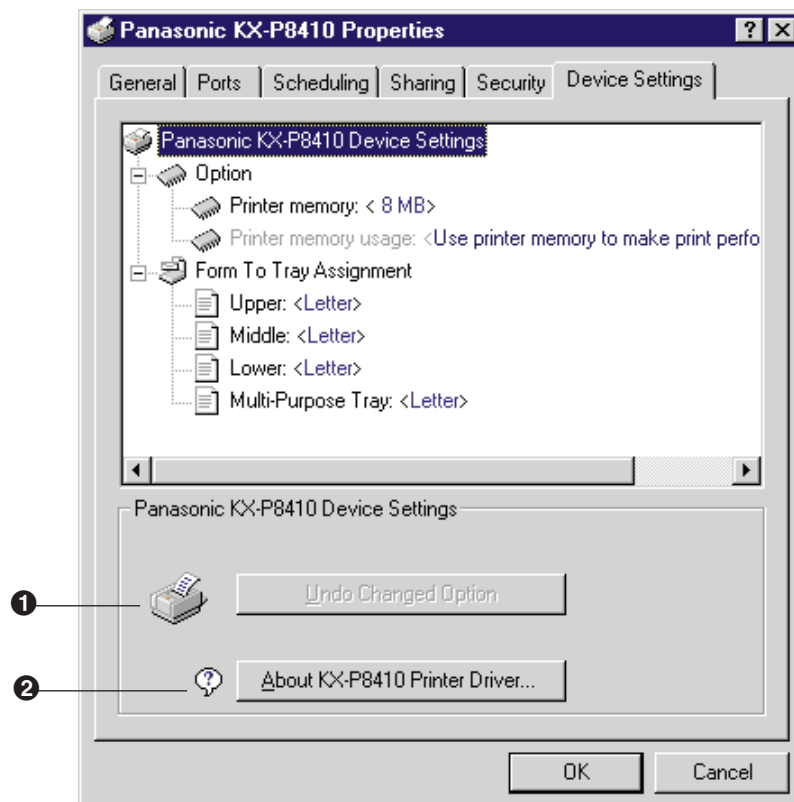

① Undo Changed Option

Returns the **Device Settings** tab's setting to the previous setting.

② About KX-P8410 Printer Driver...

Displays the window that contains the program version and copyright information.

Using the Hyper-Tetra Adjustment

You can adjust the color of your output using the **Hyper-Tetra Adjustment** window.

Displaying the Hyper-Tetra Adjustment Window

■For Windows 95 / 3.1

- 1 Click on the **Use Hyper-Tetra Adjustment** check box in the **Graphics/Color** tab ( P. 69).

The **Adjustment...** button becomes effective.

- 2 Click **Adjustment...** .
The **Hyper-Tetra Adjustment** window is displayed.

■For Windows NT 4.0

- 1 Click on **Hyper-Tetra Adjustment ...** in the **Advanced** tab ( P. 79).

The **Hyper-Tetra Adjustment...** button appears in the lower box.

- 2 Click **Hyper-Tetra Adjustment...** .
The **Hyper-Tetra Adjustment** window is displayed.

Using the Printer

Color Adjustment

To adjust the brightness, contrast, hue or saturation of color, select **Color Adjustment** in the **Hyper-Tetra Adjustment** window.

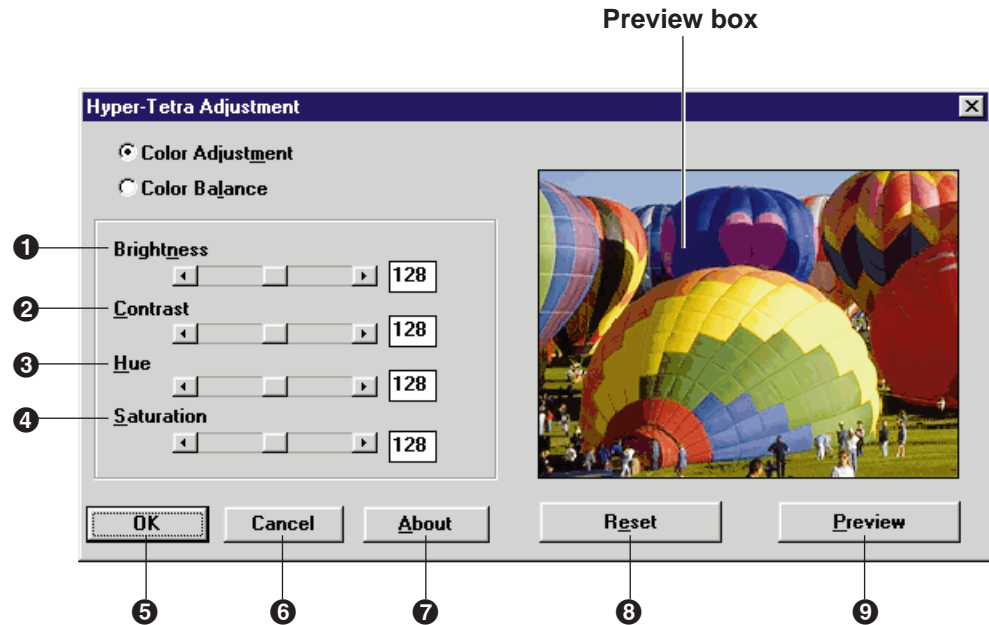

1 Brightness

Changes the brightness of an image. A higher brightness setting provides a lighter image, and a lower brightness setting provides a darker image.

2 Contrast

Adjusts the range between the darkest and the lightest shades in the image.

3 Hue

Changes the aspect of color.

4 Saturation

Changes the brightness and vividness of color. Lower saturation settings provide dull and dark image, and higher saturation settings provide bright and vivid image.

The setting range of each option (1 to 4) is from 0 to 255.

5 OK button

Makes a selection effective and closes the window.

6 Cancel button

Cancels a selection and closes the window.

7 About button

Displays the window that contains the program version and copyright information.

8 Reset button

Resets the current setting(s) made in this window to the default setting(s).

9 Preview button

Allows you to view the result of the adjustment in the **Preview box**.

Adjust the color by performing the following steps.

- 1** Drag each slider left or right or click ◀ or ▶, or type the numerical value.
- 2** Click **Preview** to see the result of the adjustment.
 - To reset the setting, click **Reset**.
- 3** Click **OK** to make the setting(s) effective.

Using the Printer

Color Balance

To adjust the level of red, green or blue, select **Color Balance** in the **Hyper-Tetra Adjustment** window. The following options appear.

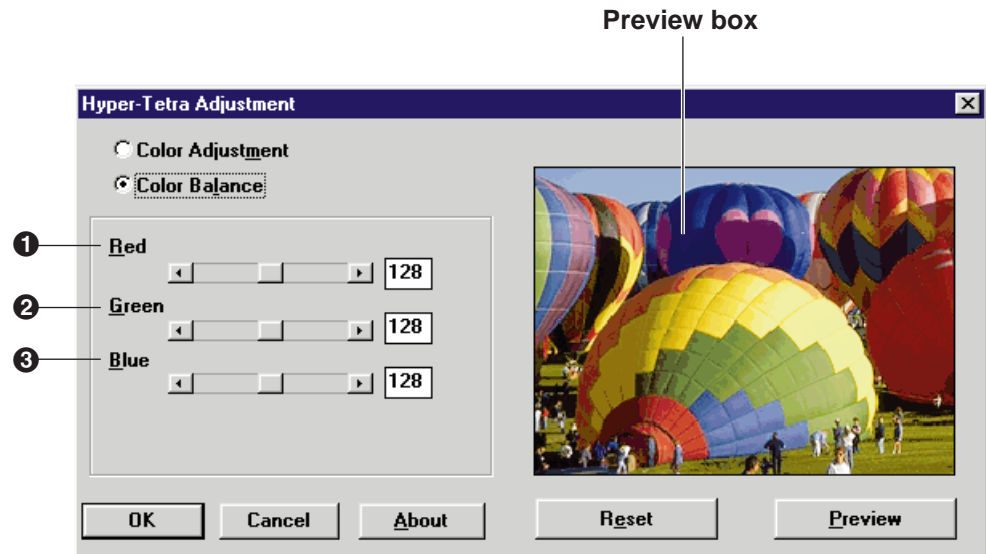

1 Red

Lightens or darkens red. Decreasing red increases cyan tones.

2 Green

Lightens or darkens green. Decreasing green increases magenta tones.

3 Blue

Lightens or darkens blue. Decreasing blue increases yellow tones.

The setting range of each option is from 0 to 255.

Adjust the color by performing the following steps.

- 1 Drag each slider left or right or click ◀ or ▶, or type the numerical value.



Darker ← → Lighter

- 2 Click **Preview** to see the result of the adjustment in the Preview box.

- To reset the settings, click **Reset**.

- 3 Click **OK** to make the setting(s) effective.

Two-Sided Printing Using Microsoft Word 95

Single sided documents can be printed on both sides of the paper using an application software, such as Microsoft Word for Windows 95. The instructions described here are only for Microsoft Word for Windows 95.

1 Open document in Word for Windows 95.

2 From the **File** menu, click **Print...**

The **Print** window is displayed.

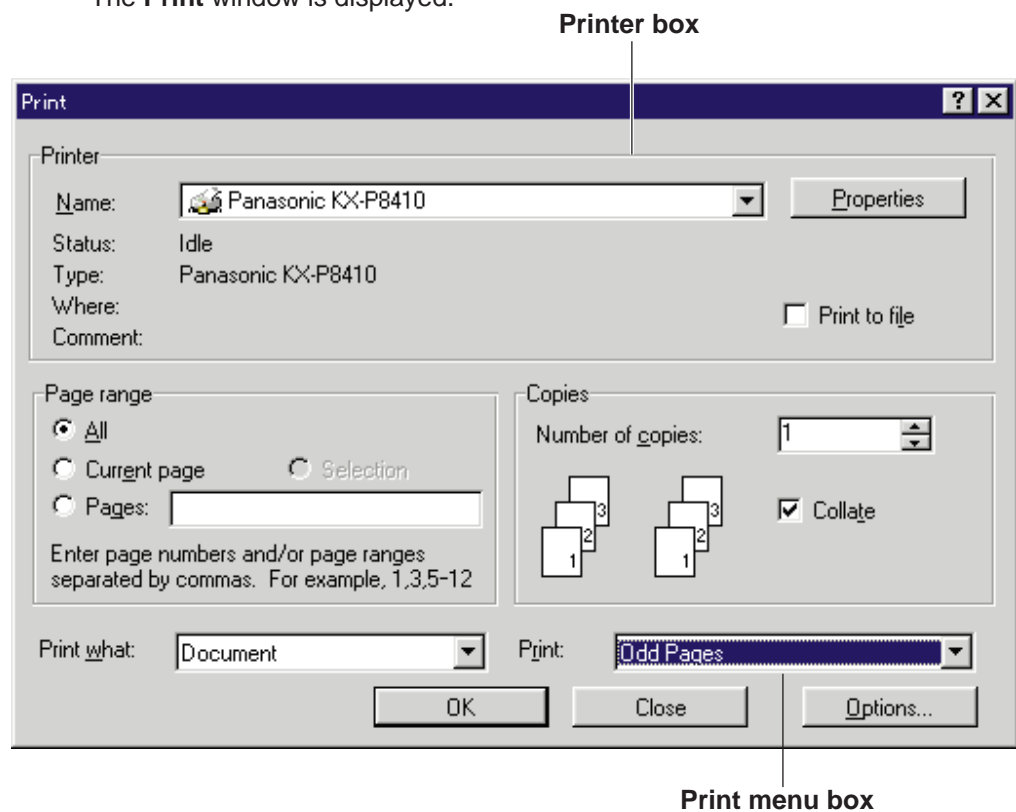

3 Make sure that **Panasonic KX-P8410** is selected in the **Printer** box, then click **Properties**.

The **Panasonic KX-P8410** window is displayed.

4 Select **Face up** in the **Output order** box, then click **OK**.

The **Panasonic KX-P8410** window is closed.

5 Select **Odd pages** from the **Print** menu box, then click **OK**. The **Print** window is closed and odd pages will be printed face up.

Using the Printer

6 Place the printed pages in the multi-purpose tray with the pages face down and top first.

7 From the **File** menu, click **Print...** .
The **Print** window is displayed.

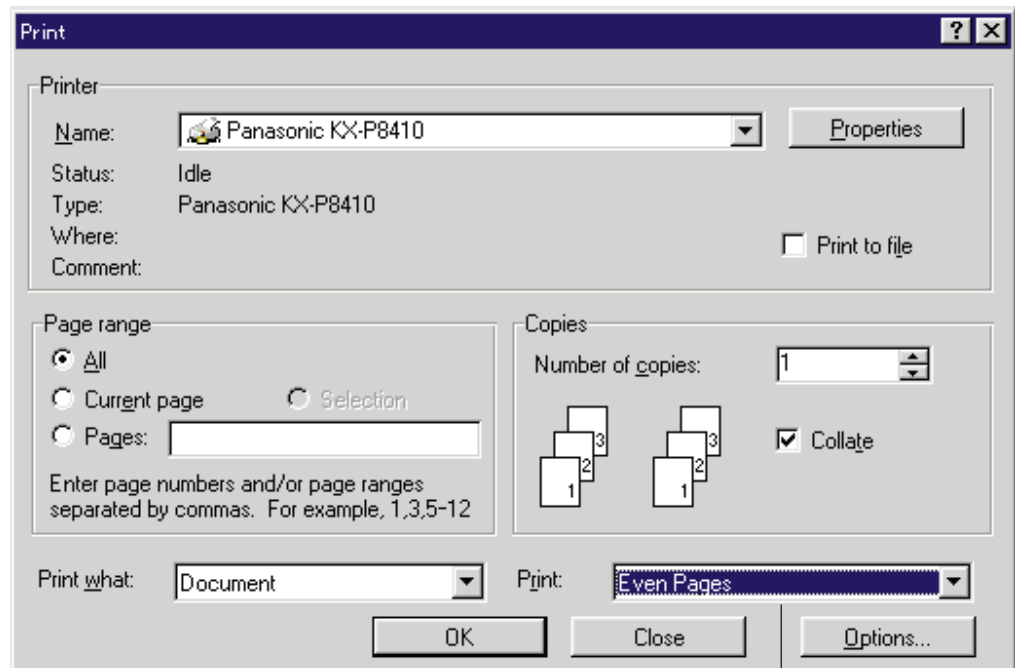

Print menu box

8 Click **Properties** .
The **Panasonic KX-P8410** window is displayed.

9 Select **MPT Paper 2nd Side** from the **Paper source** pop-up menu, then click **OK** .
The **Panasonic KX-P8410** window is closed.

10 Select **Even Pages** from the **Print** menu box, then click **OK** .
The **Print** window is closed and even pages will be printed on the back side of the paper.

Care and Maintenance

Cleaning

Periodic cleaning of the printer is recommended. The frequency of cleaning is dependent upon the environment in which the printer is used. You should clean the printer:

- At least once a month.
- When the printer experiences frequent media jams.
- When print quality has deteriorated.

■ External

- 1** Turn the power OFF.
- 2** Clean all the covers with a soft cloth. Use any mild commercial cleaner.

Caution:

- Do not use benzine, thinner, aerosol cleaners, or any abrasive powder.

■ Internal

When using isopropyl alcohol with a lint-free cloth, make sure that the alcohol is at least 90% pure, obtainable from your local pharmacy. (Do not use rubbing alcohol; it can damage the printer.)

Cleaning the paper-pick rollers

- 1** Slide the media tray out (you do not have to remove it) to allow access to the paper-pick rollers.
- 2** Open the left side door.
- 3** Use the green handles to pull out the paper feeder.

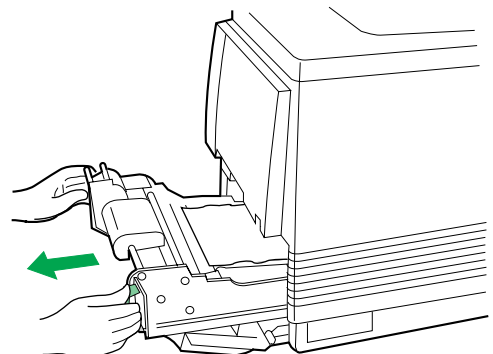
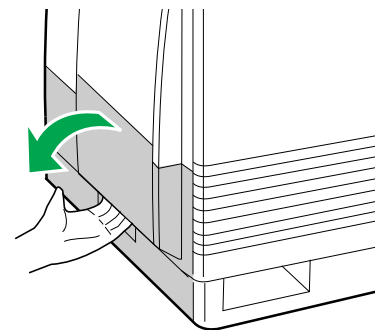

Care and Maintenance

- 4 Gently rotate the paper-pick rollers 180° (the paper-pick rollers are D-shaped) and wipe them with a lint-free cloth that has been moistened with isopropyl alcohol.

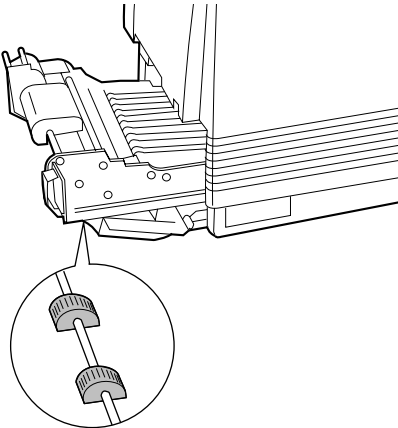

- 5 Reinsert the paper feeder (1) and close the left side door (2).

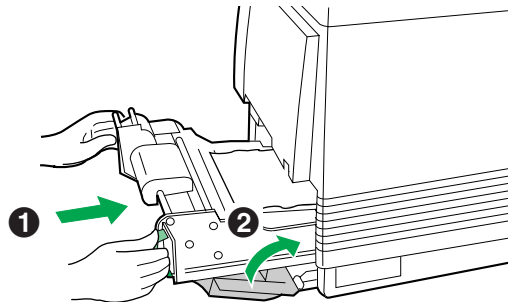

- 6 Slide the media tray back into place.

Note:

- If you have a 2nd Cassette Feeder, you may also need to clean the rollers for the middle and lower media trays, which are accessed through the **lower** left side door.

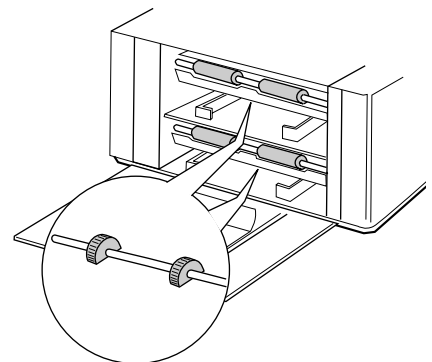

Cleaning the home sensor

If your printer panel displays Printer Error 30, clean the home sensor inside the printer.

- 1 Open the printer's front door.

2 Remove the imaging unit:

- 1 Loosen the two thumbscrews by turning them counterclockwise.
- 2 Turn the lower green lever 180° counterclockwise.

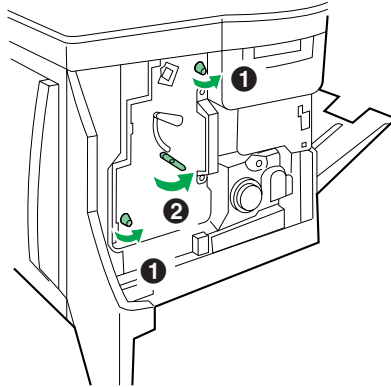

- 3 Grasping the front green handle, slide the imaging unit out until it catches.
- 4 Lift up the left green handle. Pull the imaging unit out of the printer and cover it to protect it from light exposure.

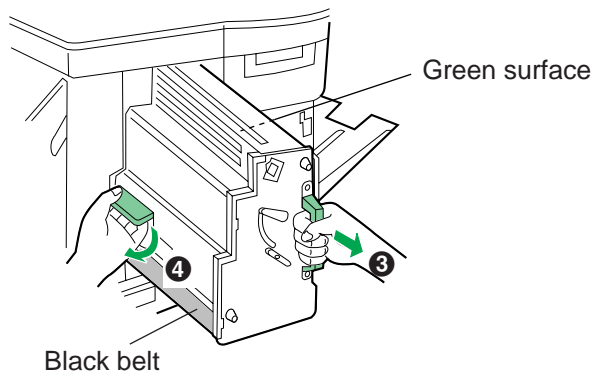

Important:

- Do not touch the green surface (the right side) or the black belt (the underside). Finger prints may affect the print quality.

Safety Caution:

- The imaging unit weighs approximately 6.5 kg {14.3 lbs.}. Always use the handles when lifting it.

Cautions:

- Do not expose the imaging unit to artificial light for more than 45 seconds; or you may damage the unit. Never expose it to direct sunlight.
- Do not leave the printer's front door open for an extended period of time (for example, several hours).

Care and Maintenance

- 3** Use a dry, lint-free cloth to wipe the slot of the sensor.

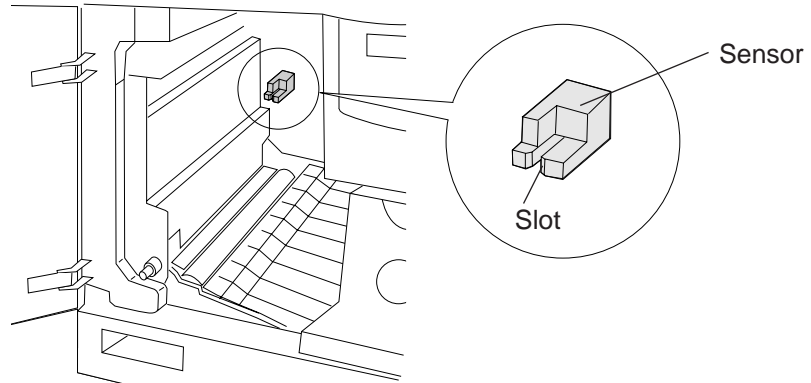

- 4** Reinsert the imaging unit into the printer, holding it by its green handles.

Match the arrow on the right side of the imaging unit with the arrow on the printer, and slightly push the imaging unit into the printer. Then release the left handle and push the unit in until it stops.

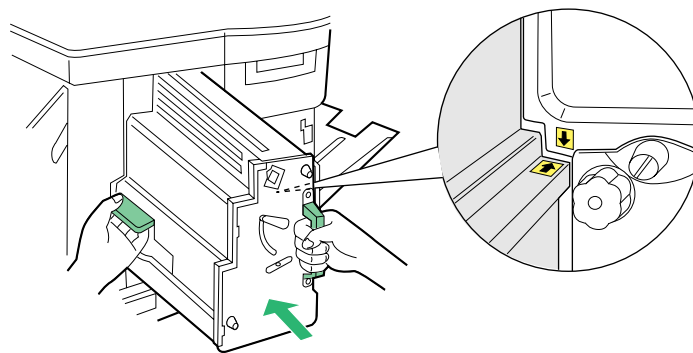

- 5**
- 1** Turn the lower green lever clockwise 180° to insert the unit completely and to lock it.
 - 2** Tighten the two green thumbscrews by turning them clockwise.
 - 3** Close the front door.

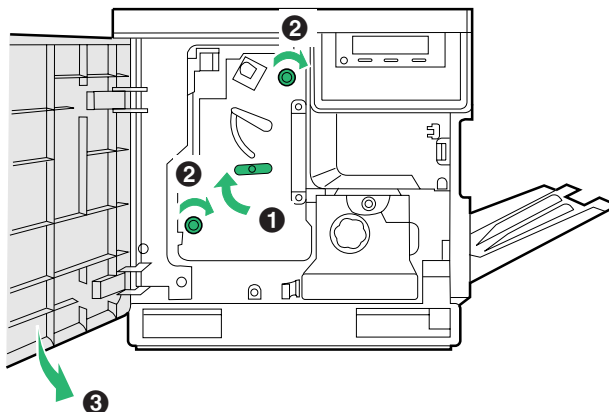

User Replaceable Components

When the printer panel indicates that a supply needs to be replaced, make sure that you have replacement supplies on hand. The printer may continue to print until the supply is completely used up; then it stops until you replace the indicated supply.

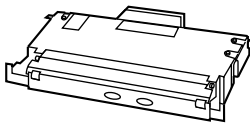
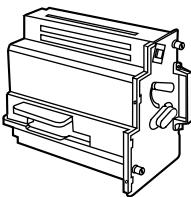
Printer component	Printer panel message	Average life* ¹
Toner cartridges 	<div style="border: 1px solid black; padding: 5px; background-color: #e0f0e0;">Low <Color> Toner</div> Change the color toner cartridge soon.	10,000 pages (CMY)* ²
	<div style="border: 1px solid black; padding: 5px; background-color: #e0f0e0;"><Color> Toner Empty</div> Change the color toner cartridge now.	12,000 pages (Black)* ²
Color imaging unit 	<div style="border: 1px solid black; padding: 5px; background-color: #e0f0e0;">Imaging Unit wearing out</div> Change the Imaging unit soon.	Monochrome 57,000 pages or Color 14,250 pages
	<div style="border: 1px solid black; padding: 5px; background-color: #e0f0e0;">Imaging Unit Worn out</div> Change the Imaging unit now.	Monochrome 60,000 pages or Color 15,000 pages



*¹ These figures are based on an average of 5% coverage of the printable area and standard density for any one color. The frequency of replacement will vary, depending on the complexity of the prints and the percentage of coverage and print density.

*² The starter cartridges that are shipped with the printer have an average life of approximately 3,000 pages, based on an average of 5% coverage.

Note:

If you print with high density when “Low <Color> Toner” is displayed, you may get faded printout before “<Color> Toner Empty” is displayed.

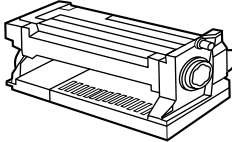
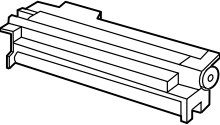
Care and Maintenance

Printer component	Printer panel message	Average life
Fuser unit *1 (Oil supply roll installed) 	<div style="border: 1px solid black; padding: 2px; display: inline-block;">Fuser Unit wearing out</div> <div style="border: 1px solid black; padding: 2px; display: inline-block; vertical-align: middle;">Oil Roll wearing out</div> <div style="font-size: 2em; vertical-align: middle; margin: 0 5px;">}</div> Display alternately	28,500 pages
	Change the Fuser unit soon. <div style="border: 1px solid black; padding: 2px; display: inline-block;">Fuser Unit and Oil Roll Worn out</div> Change the Fuser unit now.	
Oil supply roll 	<div style="border: 1px solid black; padding: 2px; display: inline-block;">Oil Roll wearing out</div> Change the Oil supply roll soon.	15,000 pages
	<div style="border: 1px solid black; padding: 2px; display: inline-block;">Oil Roll Worn out</div> Change the Oil supply roll now.	15,500 pages
Transfer unit 	<div style="border: 1px solid black; padding: 2px; display: inline-block;">Transfer wearing out</div> Change the Transfer unit soon.	80,000 pages

*1 Transparencies, coated paper and other specialty media will result in shortening the life of a consumable. When replacing the fuser unit, replace the oil supply roll as well. **Do not insert the used oil supply roll into the new fuser unit.**

Clearing a Jam

■ Clearing a media jam

If the printer has frequent media jams, make sure that you follow these guidelines:

- Always use high-quality laser paper and transparencies. Refer to [pages 156 and 157](#).
- Make sure that you load specialty media only in the multi-purpose tray and that you set the media thickness switch to the correct setting for the media used.

If a media jam occurs, the printer panel reports Jam at <Location>. The <Locations> are the various sensors throughout the paper path, listed as A through E.

The following illustration shows the locations of the sensors that report media jams (A through E).

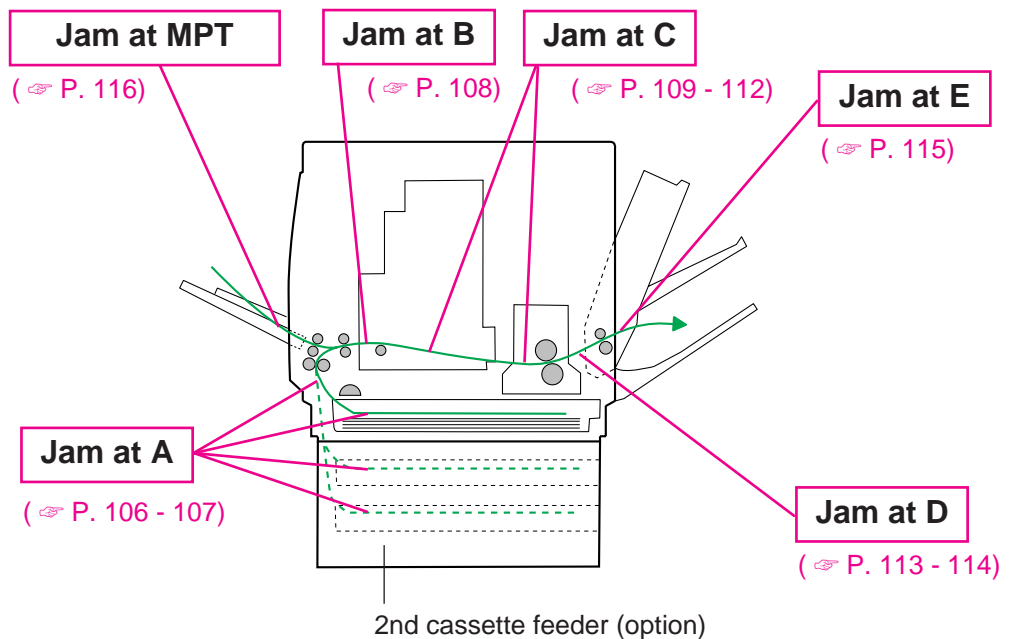

Care and Maintenance

■ Jam at A

1A ① Open the left side door corresponding to the selected media tray.

② Remove the jammed media.

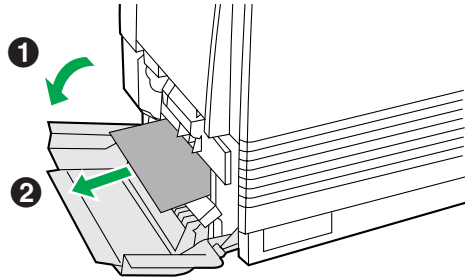

③ Close the left side door.

— OR —

① Remove the media tray.

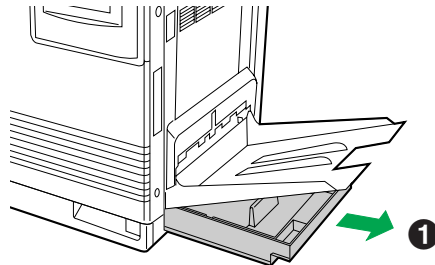

② Remove the jammed media from inside the printer.

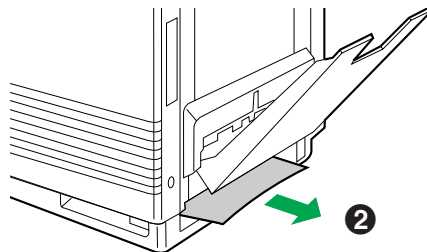

③ Reinsert the media tray.

④ Open and close the front door to clear the error message from the LCD.

(2nd cassette feeder)

- 1B** ① Open the lower left side door.

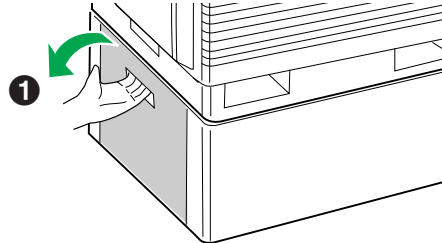

- ② Remove the jammed media.

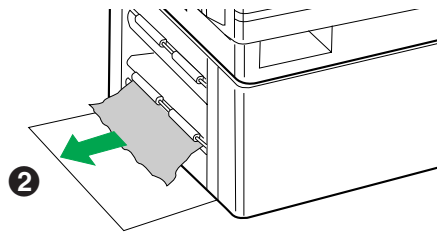

- ③ Close the lower left side door.

— OR —

- ① Remove the selected media tray (middle or lower media tray).

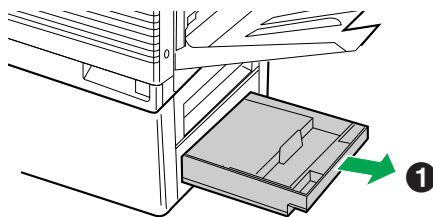

- ② Remove the jammed media from inside the printer.

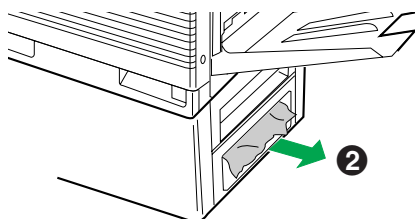

- ③ Reinsert the media tray.

- ④ Open and close the front door to clear the error message from the LCD.

Care and Maintenance

■ Jam at B

- 1 Open the left side door.

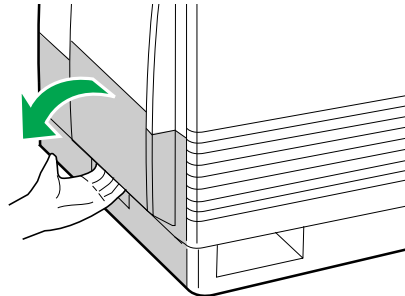

- 2 Use the green handles to pull out the paper feeder.

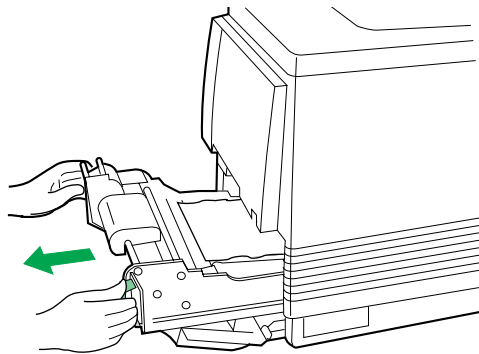

- 3 Remove the jammed media on the paper feeder.

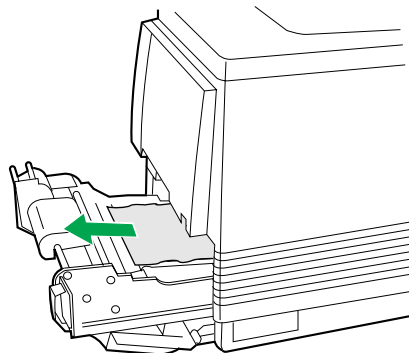

- 4 Reinsert the paper feeder and close the left side door.

■ Jam at C

1 Remove the fuser:

- 1 Open the printer front door.
- 2 Turn the small green thumbscrew counterclockwise to unlock the fuser.

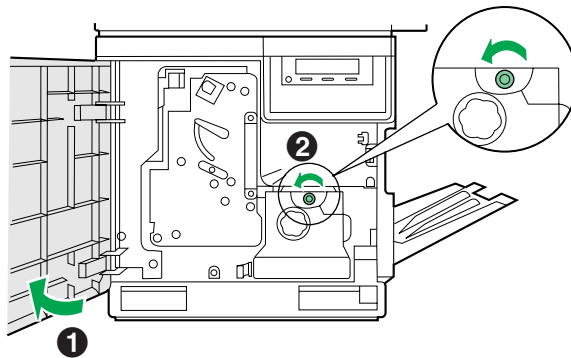

Safety Caution:

- *The fuser is hot; to avoid personal injury, turn off the printer and wait 10 minutes (after opening the front door) for the fuser to cool before touching it.*

- 3 Holding the green tab on the right, slide the fuser out until the safety catch stops it.
- 4 Press the green lever on the left to release the safety catch.

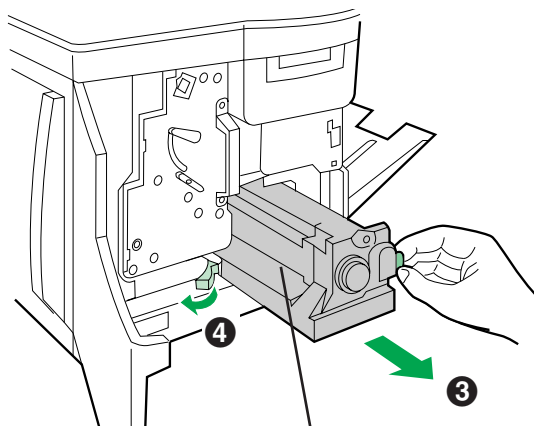

CAUTION:
HOT SURFACE INSIDE

Care and Maintenance

- 2** ① Hold the fuser as shown below, and slide it out of the printer.

Safety Caution:

- The fuser unit weighs approximately 3.1 kg {6.8 lbs.}. Take care when handling it.

- 2** ② Close the front door.

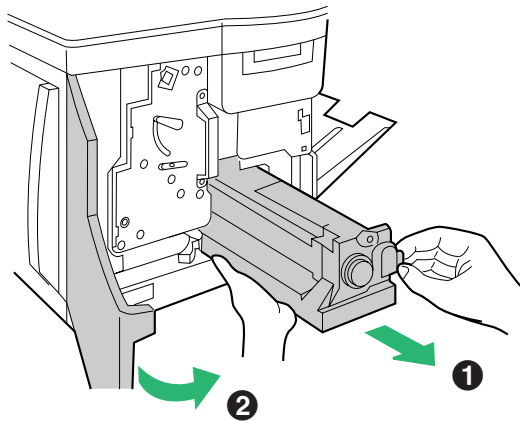

- 3** Remove the oil supply roll:

- ① Press out on tabs to unlock the oil supply roll.
② Remove the oil supply roll out of the fuser.

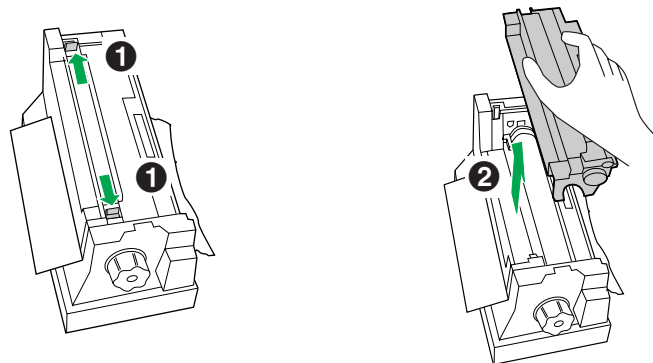

Note:

- If the paper is not jammed in the fuser unit, perform the following.
① Repeat steps 1 to 4 of Jam B on [page 108](#).
② Skip step 4 and go to step 5.

- 4** ① Turn the fuser's large green knob clockwise.
② Remove the jammed media.

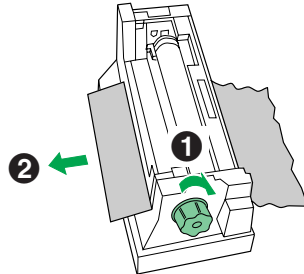

- 5** ① Replace the oil supply roll into the fuser.
② Press down firmly on the oil supply roll to snap both sides into place.

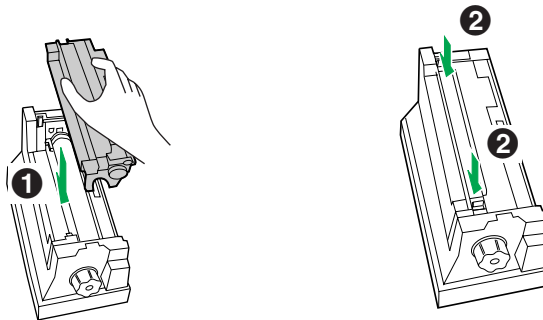

Caution:

- If the oil supply roll is not installed correctly, print quality will be diminished.

- 6** ① Open the front door.
② Slide the fuser back into the printer.

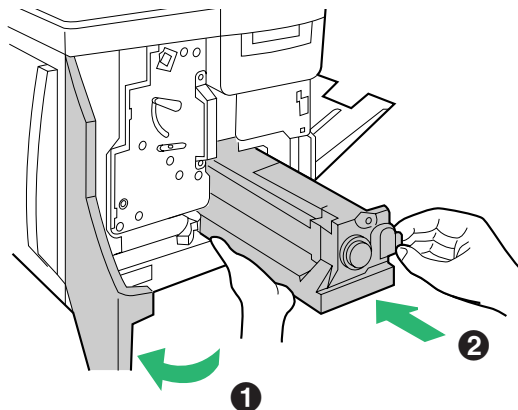

Care and Maintenance

- 7** **1** Turn the small green thumbscrew clockwise to lock the fuser.
- 2** Close the front door.

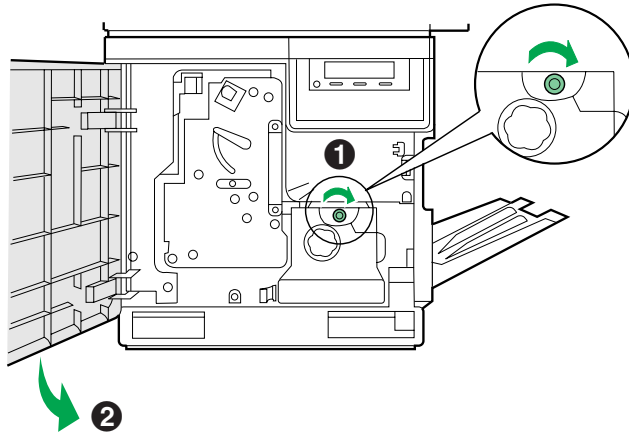

■ Jam at D

Safety Caution:

- The fuser is hot. To avoid personal injury, turn off the printer and wait 10 minutes (after opening the front door) for the fuser to cool before touching it.

Note:

- First check the exit opening for media that has jammed and folded like an accordion. It is especially difficult to see if the media is transparency film.

1A (Printing face down)

- ➊ Open the front door.
- ➋ Pull open the access door (above the plastic output tray); see if the media is visible.

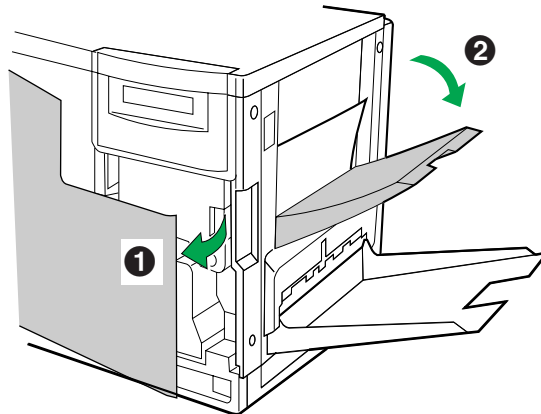

- ➌ Turn the large green knob on the fuser counterclockwise.
- ➍ Remove the media from inside the access door.

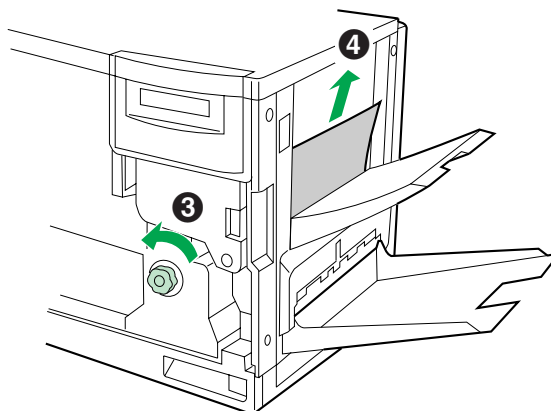

Care and Maintenance

Caution:

- If the fuser knob will not turn, do not force it, or you may damage the fuser. Instead, follow these steps:
 - a) Unlock the fuser by turning the small green thumbscrew counterclockwise.
 - b) Pull the fuser out. The media will probably tear.
 - c) Remove the oil supply roll.
 - d) Turn the fuser's large green knob to release the jammed media.
 - e) Remove the jammed media from the fuser and the printer.

Safety Caution:

- The fuser is hot; to avoid personal injury, turn off the printer and wait 10 minutes for the fuser to cool before touching it.

- 5 Close the front door.

1B (Printing face up)

- 1 Open the front door and the right side door.
- 2 Turn the fuser's large green knob counterclockwise to release the jammed media.
- 3 Remove the jammed media from the right side of the printer.

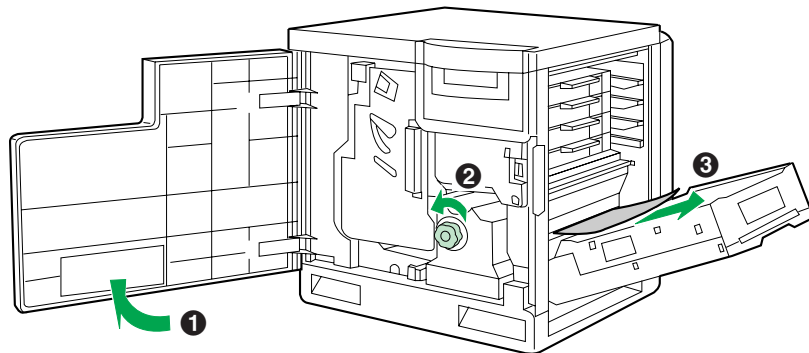

- 4 Close the front door and the right side door.

■ Jam at E

- 1** Remove the jammed media from the output tray.

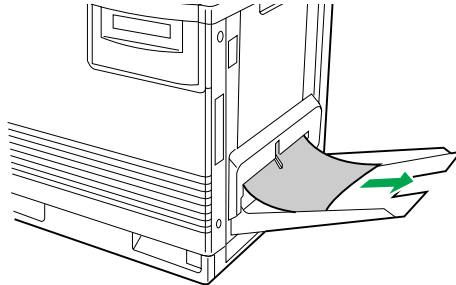

— OR —

Pull open the access door (above the plastic output tray) and remove the media.

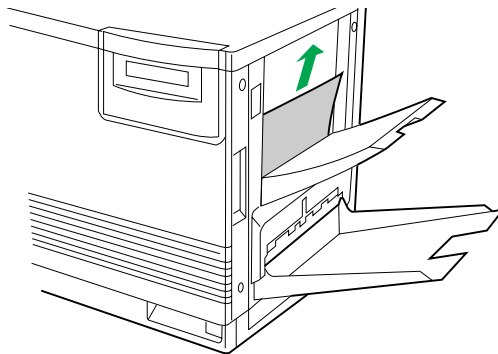

- 2** Open and close the front door to clear the error message from the LCD.

Care and Maintenance

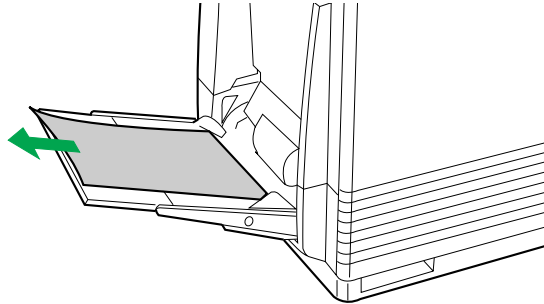

■ Jam at MPT (Multi-purpose tray)

- 1** Remove the jammed media from the multi-purpose tray.

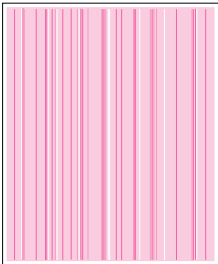

- 2** Open and close the front door to clear the error message from the LCD.

Troubleshooting

Trouble	Possible Cause	Corrective Action
READY indicator is blinking.	The printer is receiving, processing or printing job.	Wait for the job to be completed or cancel the job.
	You have entered the Menu mode in the printer panel.	Exit the Menu mode by pressing the MENU/EXIT button.
READY indicator is off.	The printer is not ready, is disabled, or has detected an error.	Read the printer panel message to determine the printer status.
ERROR indicator is on.	Error occurred that is not user-correctable.	Turn the printer off and back on again. If the indicator is still on, the printer requires service.
ERROR indicator is blinking.	The printer has stopped because it detected a user-correctable error such as an open door or a media jam.	Correct the condition displayed on the printer panel (e.g., close the door or clear the media jam).
<p>A single color is not uniform or many vertical streaks (both light and dark) of slightly different density and non-uniform color.</p> 	The toner is almost depleted.	Replace the color toner cartridge.
<p>Half tone area has areas of weak color.</p> 	Paper doesn't match the environmental conditions, or it has too much moisture.	Try fresh paper, or another type of paper.
		Store media in the original, dust-free package in the same environmental conditions as the printer.

Care and Maintenance

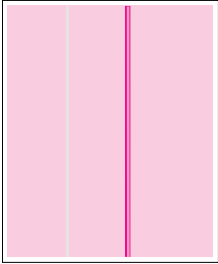
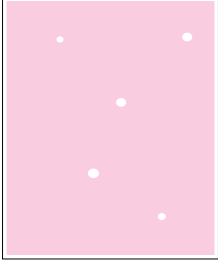
Trouble	Possible Cause	Corrective Action
<p>A single color appears faded.</p>	<p>The color density is set incorrectly in the printer panel.</p>	<p>Check the density setting by printing the Color Calibration Page in the Color Calibration menu from the printer panel. Compare the settings with the color density samples on the Color Calibration Card and, if necessary, adjust the density from the printer panel. Refer to Setting the Color Density on page 54.</p>
	<p>The toner is almost depleted.</p>	<p>Replace the color toner cartridge soon (depending on the complexity of your prints, you can continue to print up to 100 more pages).</p>
<p>A single color has a sharp, dark or light vertical streak.</p> 	<p>The toner cartridge is almost depleted and is not properly applying toner.</p>	<p>Replace the color toner cartridge.</p>
<p>Small white spots appear on OHP transparency.</p> 	<p>OHP transparency has dust on its surface.</p>	<p>Remove dust or stain from OHP transparency.</p>

Care and Maintenance

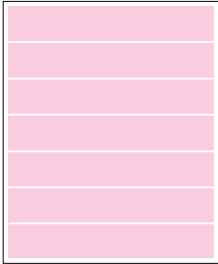
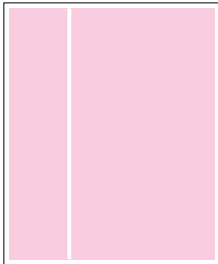
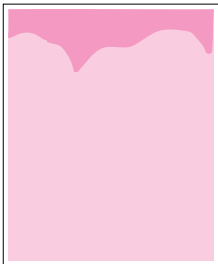
Trouble	Possible Cause	Corrective Action
<p>A single color shows a light, repeating horizontal line.</p> 	<p>The roller in the toner cartridge has a slight impression after a long period of storage.</p>	<p>Run 20-30 prints. The impression will disappear with continued time and use.</p>
<p>Prints are missing fine-line detail.</p>	<p>The imaging unit has reached its useful life.</p>	<p>Replace the imaging unit.</p>
<p>Dark color spots and dark or light streaks appear in all colors.</p>	<p>The imaging unit has reached its useful life.</p>	<p>Replace the imaging unit.</p>
<p>Straight, thin light vertical line in colors.</p> 	<p>The photosensitive belt inside the imaging unit is scratched.</p>	<p>Replace the imaging unit.</p>
<p>Each color "bleeds" into the color band.</p> 	<p>The imaging unit's internal waste toner box is full.</p>	<p>Replace the imaging unit.</p>

Care and Maintenance

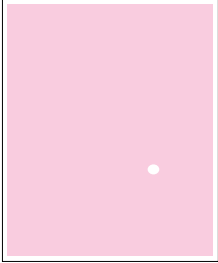
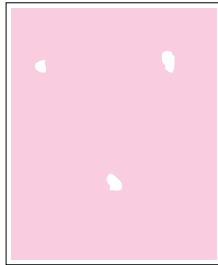
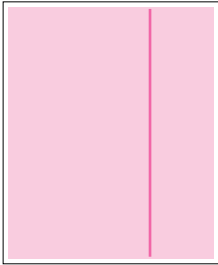
Trouble	Possible Cause	Corrective Action
<p>A single white spot appears in approximately the same vertical place on the page.</p> 	<p>The imaging unit is damaged.</p>	<p>Replace the imaging unit.</p>
<p>Large light spot(s) appear randomly.</p> 	<p>Fingerprint(s) on the underside belt or photosensitive belt (inside) of the imaging unit.</p>	<p>Print several pages until the spots fade.</p>
<p>One or more dark vertical lines appear on the print in all colors.</p> 	<p>The imaging unit is scratched.</p>	<p>Replace the imaging unit; make sure that the old imaging unit is not exposed to light for more than 45 seconds. If a new imaging unit does not correct the problem:</p> <ul style="list-style-type: none"> ● Put the old imaging unit back into the printer. ● Repack the new imaging unit.
	<p>The fuser is damaged.</p>	<p>Replace the fuser.</p>

Care and Maintenance

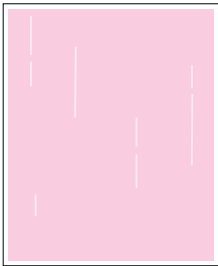
Trouble	Possible Cause	Corrective Action
<p>A piece of the printed image is missing and reappears out of place, approximately 129 mm (5") down the page.</p>	<p>The fuser's internal roller is not being consistently oiled. or The fuser's internal roller is contaminated with toner particles.</p>	<p>Print 5-10 pages of blank pages to clean the roller. If you still see the problem: <ul style="list-style-type: none"> ● Replace the oil supply roll. If you still see the problem: <ul style="list-style-type: none"> ● Replace the fuser. </p>
<p>The surface of the printed image appears to have vertical scratches (visible by holding the print at an angle and observing the "shine" of the image). At first, the scratches appear only on the printed image; eventually, dark vertical scratches appear on the unprinted portion of the page.</p>	<p>The fuser is near its useful life.</p>	<p>Replace the fuser (depending on your quality needs, you can continue to print until the dark vertical lines appear).</p>
<p>Media frequently wraps around the fuser.</p>	<p>The oil supply roll has reached its useful life.</p>	<p>Replace the oil supply roll.</p>
<p>Light vertical streaks appear in all colors.</p> 	<p>The main charge grid is dirty.</p>	<p>Replace the imaging unit.</p>

Care and Maintenance

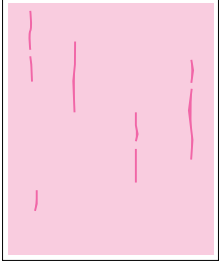
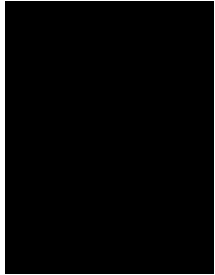
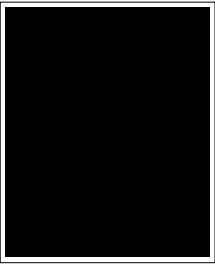
Trouble	Possible Cause	Corrective Action
<p>Dark and wavy vertical streaks appear in all colors.</p> 	<p>The main charge grid is dirty.</p>	<p>Replace the imaging unit.</p>
<p>The entire page prints in black, including the borders.</p> 	<p>Bad electrical contact for the main charge grid.</p>	<p>Reinsert the imaging unit to correct the contact for the main charge grid.</p>
	<p>The main charge grid is broken.</p>	<p>Replace the imaging unit.</p>
<p>Toner spots appear on the back of the media.</p>	<p>The transfer unit is worn out.</p>	<p>Replace the transfer unit.</p>
<p>The page prints in black in the image area only. (The borders are clear.)</p> 	<p>Either the image processor board or engine control board is not functioning properly.</p>	<p>Turn the printer off and back on again. If the problem persists, call for service on your printer.</p>

Care and Maintenance

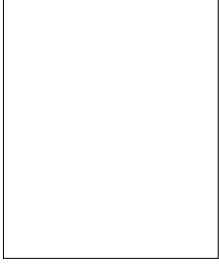
Trouble	Possible Cause	Corrective Action
The page is completely blank. 	The problem could be with one of the following: <ul style="list-style-type: none">• Engine control board.• Developer voltage.• Laser scanning unit mirror.	Turn the printer off and back on again. If the problem persists, call for service on your printer.
Service Error is displayed on the LCD.	An error occurred that is not user-correctable.	Turn the printer off and back on again. If the error persists, call for service.

Care and Maintenance

■ If you can't make a print

Trouble	Corrective Action
Printer not operating.	Make sure that you plugged in the printer and turned it on.
	Make sure that you connected the interface cable(s) properly.
More info to come for these messages.	If the communication link between your computer and the printer is working but the printer ejects a blank page when printing from your application or through Windows. Make sure that the appropriate driver is installed and that you have selected the printer correctly.

Trouble	Possible Cause	Corrective Action
The printer does not print correctly.	The computer is not properly communicating with the printer.	<p>Follow the procedure below and disable the bi-directional interface. (The Status Display function becomes ineffective.)</p> <p>Windows 95:</p> <ol style="list-style-type: none"> 1. Click Start, select Settings, then click Printers. 2. Click the Panasonic KX-P8410 icon. 3. Click the File menu, then click Properties. 4. Click the Details tab and Spool settings... 5. Click Disable bi-directional support for this printer, then click OK. <p>Windows 3.1:</p> <ol style="list-style-type: none"> 1. Double-click Status display setup icon in the KX-P8410 Utilities program group. 2. Click the Device tab. 3. Click off the Monitor Printer check box. 4. Click OK. <p>Windows NT 4.0:</p> <ol style="list-style-type: none"> 1. Click Start, select Settings, then click Printers. 2. Click the Panasonic KX-P8410 icon. 3. Click the File menu, then click Properties. 4. Click the Ports tab. 5. Click off the Enable bidirectional support check box. 6. Click OK.

■Media problems

Trouble	Corrective Action
Frequent paper-picking errors.	Fan the paper or transparencies before installing them in their respective trays; this is especially important for transparencies because they tend to stick together.
	Make sure that you have loaded paper in the paper tray and transparencies in the transparency tray.
	Make sure that the media is installed under the hooks at the front of the media tray.
	If printing on transparencies and your printer has a 2nd Cassette Feeder, make sure that the transparency tray is installed in the upper or middle tray slot.
	Clean the paper-pick rollers (☞ P. 99 for instructions).
Frequent media jams.	Make sure that you use a high-quality laser paper: 60-105 g/m ² (16-28 lbs.) paper in the media trays and 75-165 g/m ² (20-44 lbs.) paper in the multi-purpose tray.
	If you are using media that is 105 g/m ² (28 lbs.), check if the Face Down media output setting is selected in the driver. If it is, change the setting to Face Up.
	Use only recommended transparencies (☞ P. 157). We cannot guarantee the results of other transparencies.
	Make sure that the media is installed under the hooks at the front of the media tray.
	Do not overfill the media tray, as indicated by the red line on the right side of the tray.
	Clean the paper-pick rollers (☞ P. 99 for instructions).
	Make sure that the media thickness switch is set correctly for the installed media (☞ P. 29).

■Problems with image size and position

Trouble	Corrective Action
Off-set images.	Check your application for correct image sizing.
Cut-off images.	Check your application for image sizing.
	Make sure that the correct size media is in the media tray.

Care and Maintenance

■ Print quality problems

Trouble	Corrective Action
Prints have dull, faded colors.	Print the Color Calibration Page from the Color Calibration menu in the printer panel. Check the density settings for each color and compare them to the examples on the Color Density Samples. Refer to Setting the Color Density on page 54 for instructions on comparing and setting color density.
	Make sure that the imaging unit stays covered until immediately before installing it in the printer. Exposure to light can damage the imaging unit and will produce light streaks or faded prints.
	Make sure that the toner cartridges are installed correctly.
	Make sure that you use a high-quality laser paper: 60-105 g/m ² (16-28 lbs.) paper in the media trays and 75-165 g/m ² (20-44 lbs.) paper in the multi-purpose tray.
Image is very faded or pieces of the image are missing; toner on the page is loose.	When using the multi-purpose tray, make sure that you have selected the correct media type in the driver or in the Menu mode of the printer panel.
Streaks or spots	Most spots are caused by fingerprints or dust introduced into the printer while installing the imaging unit or loading media. Make sure that the surface where you unpack the imaging unit, paper, and transparencies is free of dust. Keep supplies in a covered area or a closed box.
	Make sure that the imaging unit stays covered until immediately before installing it in the printer. Exposure to light for more than 45 seconds can damage the imaging unit.
	Do not touch the right side or underside of the imaging unit; fingerprints affect print quality.
	Make sure that the paper or transparency film is clean.
	Make sure that you handle the media on the outside edges to avoid fingerprints.
	To get rid of fingerprint spots, print a few prints.
The back of the printed page appears dirty.	Toner particles have contaminated the transfer roller. This can happen if the printed image is larger than the media (for example, when printing on envelopes). Run 10-20 prints to clean the transfer roller.
The print quality of a transparency is poor.	There is a defect on the coated surface of the transparency. Print on the other side.

SCSI

If trouble occurs when printing using SCSI, confirm that the ASPI Manager is installed. If the ASPI Manager is not installed, you must install it. It is assumed that the Adaptec SCSI host adapter is installed.

■Windows 3.1 users

- 1** Confirm that the SCSI host adapter is installed in your PC correctly.
- 2** In CONFIG.SYS file, check the following setting.
DEVICE = ASPIInDOS.SYS (n = 2, 4, 8 etc.)
If this setting does not exist in CONFIG.SYS, reinstall SCSI driver using EZ-SCSI (refer to the SCSI host adapter users manual).
- 3** Confirm that the EZ-SCSI is installed in Windows 3.1. If Adaptec EZ-SCSI program group does not exist, install SCSI driver using EZ-SCSI (refer to SCSI host adapter users manual).
- 4** After finishing necessary procedure, restart PC and make sure that the following message appears on your PC.

“ASPIInDOS.SYS Installation successful”
- 5** Start Windows and confirm that the printer is recognized by PC using SCSI utility in EZ-SCSI program group or **Show configuration** in **KX-P8410 Utilities** program group.

If the printer is not recognized, please recheck SCSI ID or terminator settings.

Care and Maintenance

■Windows 95 users

- 1** Confirm that the SCSI host adapter is installed in your PC correctly.
- 2** Click **Start** and select **Settings**, then click **Control Panel**.
- 3** Double-click the **System** icon from the Control Panel.
- 4** Click **Device Manager** tab.
If the SCSI host adapter does not exist or displayed with the exclamation mark !, SCSI driver is not installed correctly. Reinstall the SCSI driver (refer to SCSI host adapter users manual).
- 5** If the SCSI driver is installed correctly, confirm that the printer is recognized by the PC using Show SCSI utility in EZ-SCSI program group or **Show configuration** in **KX-P8410 Utilities** program group.

If the printer is not recognized, please recheck the SCSI ID or terminator settings.

■ Windows NT 4.0 users

- 1** Confirm that the SCSI host adapter is installed in your PC correctly.

- 2** Click **Start** and select **Settings**, then click **Control Panel**.

- 3** Double-click the *SCSI Adapters* icon from the Control Panel.
If the SCSI host adapter does not exist, SCSI driver is not installed correctly. Reinstall the SCSI driver (refer to SCSI host adapter users manual).

- 4** If the SCSI driver is installed correctly, confirm that the printer is recognized by PC using SCSI utility in EZ-SCSI program.

If the printer is not recognized, please recheck the SCSI ID or terminator settings.

Care and Maintenance

Error Messages

Printer LCD Panel

Error Message	Possible Cause	Corrective Action
Jam at A See front door label	A jam has occurred in the media feed area.	Refer to page 106 to clear the jam.
Jam at B See front door label	A jam has occurred in the media feed area.	Refer to page 108 to clear the jam.
Jam at C See front door label	A jam has occurred in the fuser unit.	Refer to page 109 to clear the jam.
Jam at D See front door label	A jam has occurred inside the access door or the right side door.	Refer to page 113 to clear the jam.
Jam at E See front door label	A jam has occurred in the output area.	Refer to page 115 to clear the jam.
Jam at MPT See front door label	A jam has occurred in the multi-purpose tray.	Refer to page 116 to clear the jam.
Front or Right door Open	Front or right side door is open.	Close the front or right side door.
Left side door Open	Left side door is open.	Close the left side door.
Lower Left side door Open	Optional cassette side door is open.	Close the optional cassette side door.
Upper Left side door Open	Standard cassette side door is open.	Close the left side door.
Black Toner Cartridge Not installed	Black toner cartridge is not installed.	Install the black toner cartridge.
Cyan Toner Cartridge Not installed	Cyan toner cartridge is not installed.	Install the cyan toner cartridge.
Magenta Toner Cartridge Not installed	Magenta toner cartridge is not installed.	Install the magenta toner cartridge.
Yellow Toner Cartridge Not installed	Yellow toner cartridge is not installed.	Install the yellow toner cartridge.
Imaging Unit Not installed	Imaging unit is not installed.	Install the imaging unit.
Fuser Unit Not installed	Fuser unit is not installed.	Install the fuser unit.
Paper feeder Not installed	Paper feeder is not installed.	Install the paper feeder.
Oil Roll Not installed	Oil supply roll is not installed.	Install the oil supply roll.
Imaging Unit No tension	Imaging unit is not installed correctly.	Install the imaging unit correctly.
Charger Not installed	Charger is not installed.	Install the charger.

Care and Maintenance

Error Message	Possible Cause	Corrective Action
All Media Tray missing or empty	All media trays are missing or empty.	Install a media tray with media in it.
Media Tray Empty	Media tray is missing or empty	Install the media tray with media in it.
Upper Tray Empty	Media tray is empty.	Install media in the upper media tray.
Middle Tray Empty	Middle tray is empty in the 2nd cassette feeder option.	Install media in the middle media tray.
Lower Tray Empty	Lower tray is empty in the 2nd cassette feeder option.	Install media in the lower media tray.
Multi-Purpose Tray Empty	Multi-purpose tray is empty.	Install media in the multi-purpose tray.
Paper Tray Empty	No media tray is installed or media tray is empty.	Install a media tray with paper in it.
Transparency Tray Empty	No media tray is installed or media tray is empty.	Install a media tray with transparencies in it.
Output Tray Full	Output tray is full.	Remove the printed media from the output tray.
SIMM Check Error	Controller Optional SIMM check error.	Call for service.
SCSI error	Communication cannot be established between the printer and your computer.	Connect the SCSI cable correctly.
Ethernet Card Check Error	Printer Ethernet Card I/F Error.	Install the Ethernet Card correctly.
Imaging Unit Worn out	Imaging unit is worn out.	Replace the imaging unit now.
Imaging Unit wearing out	Imaging unit is wearing out.	Replace the imaging unit soon.
Transfer wearing out	Second transfer roller is wearing out.	Replace the transfer roller soon.
Fuser Unit and Oil Roll Worn out	Fuser is worn out.	Replace the fuser unit now.
Fuser Unit wearing out	Fuser is wearing out.	Replace the fuser unit soon.
Oil Roll Worn out	Oil supply roll is worn out.	Replace the oil supply roll now.
Oil Roll wearing out	Oil supply roll is wearing out.	Replace the oil supply roll soon.
Black Toner Empty	Black toner cartridge is empty.	Replace the black toner cartridge now.

Care and Maintenance

Error Message	Possible Cause	Corrective Action
Cyan Toner Empty	Cyan toner cartridge is empty.	Replace the cyan toner cartridge now.
Magenta Toner Empty	Magenta toner cartridge is empty.	Replace the magenta toner cartridge now.
Yellow Toner Empty	Yellow toner cartridge is empty.	Replace the yellow toner cartridge now.
Low Black Toner	Black toner cartridge is almost empty.	Replace the black toner cartridge soon.
Low Cyan Toner	Cyan toner cartridge is almost empty.	Replace the cyan toner cartridge soon.
Low Magenta Toner	Magenta toner cartridge is almost empty.	Replace the magenta toner cartridge soon.
Low Yellow Toner	Yellow toner cartridge is almost empty.	Replace the yellow toner cartridge soon.
Too hot to print Label Remove Label, Cancel job	The printer is too hot or room temperature is too high to print Labels.	Wait until the printer cools down, or use in a cooler place [below 32.5°C (90.5°F)].

Printer Driver For Windows 3.1

Error message	Possible cause	Recovery
ASPI does not support this mode!!	SCSI board and its driver are not installed correctly.	Correctly install the SCSI board and its driver. (Refer to the manual of the SCSI board.) For any other trouble related to SCSI , refer to the SCSI section of Care and Maintenance (☞ P. 127).
ASPI is not initialized!!		
Block 16 table open error: Table file not open!	1/16 compression table is not found.	Reinstall the KX-P8410 software.
KX-P8410 is already used by other devices.	The printer is being used by another device.	<ul style="list-style-type: none"> ● Reprint later when the printer is free from other jobs. ● Turn off the printer and the computer, then turn them on again.
KX-P8410 is not detected. Selected port is LPT. Please check LPT cable, Power ON or Printer condition.	The printer connected with the parallel cable is not recognized.	Check the cable connection of the printer or turn on the printer.
KX-P8410 is not detected. Selected port is SCSI. Please check SCSI cable, Power ON or Printer condition	KX-P8410 is not recognized as a SCSI device.	Check the cable connection of the system or turn on the printer.
KX-P8410 or Printer Driver is illegal condition. Abort printing.	An illegal error has occurred.	<ul style="list-style-type: none"> ● Confirm the SCSI board is correctly installed in the computer or cable is correctly connected. ● Turn off the computer, then turn it on again.
LPT Port or KX-P8410 is busy.	The printer is printing.	<ul style="list-style-type: none"> ● Reprint later when the printer is free from other jobs.
Memory is allocated Above 16MB. If your SCSI controller is connected in an ISA slot, Printing may not print correctly!!	The transfer data area for printing has allocated more than 16MB.	Close all applications and turn off the computer, then turn it on again.

Care and Maintenance

Error message	Possible cause	Recovery
No ASPI managers were found!!	SCSI board and its driver are not installed correctly.	Correctly install the SCSI board and its driver. (Refer to the manual of the SCSI board.) For any other trouble related to SCSI , refer to the SCSI section of Care and Maintenance (📖 P. 127).
One or more ASPI for DOS managers are loaded which do not support ASPI for WIN16!!		
Printing aborted for occurred SCSI error.	An illegal error has occurred.	<ul style="list-style-type: none"> ● Confirm the SCSI board is correctly installed in the computer or cable is correctly connected. ● Turn off the computer, then turn it on again.
SCSI Error!! Time Out occurred.	The printer is not responding.	Turn off the printer and the computer, then turn them on again. Print the document again.
Unable to Allocate Memory	The computer's internal memory for printing is insufficient.	<ul style="list-style-type: none"> ● Close all applications except for the one which controls the printer, then print again. ● Turn off the computer, then turn it on again.
*.DLL function Error	The necessary file for printing is not found.	Reinstall the KX-P8410 software.
*.DLL not found		

■ Some application settings may take priority over the printer driver settings.

Printer Driver For Windows 95

Error message	Possible cause	Recovery
ASPI Manager is not found. Install ASPI for Windows. (e.g. install wnaspi32.dll to your windows (system directory).)	SCSI board and its driver are not installed correctly.	Correctly install SCSI board and its driver. (Refer to the manual of the SCSI board.) wnaspi32.dll will be installed or replaced with a new version.
Can not find Panasonic KX-P8410. Make sure that Panasonic KX-P8410 is connected to your PC by SCSI, and then retry again.	<ul style="list-style-type: none"> ● Cable connection is improper or printer is not ready. ● The terminator setting is improper. 	Perform the following procedure. <ol style="list-style-type: none"> 1. Confirm that the terminator is correctly set. 2. Confirm that the printer is ready. 3. Confirm that the printer is correctly connected with a SCSI cable. 4. Turn off the computer, then turn it on again.
Can not initialize ASPI for Windows. Install newer version of ASPI for Windows	SCSI board and its driver are not installed correctly.	Correctly install the SCSI board and its driver. (Refer to the manual of the SCSI board.) wnaspi32.dll will be installed or replaced with a new version. For any other trouble related to SCSI , refer to the SCSI section of Care and Maintenance (☞ P. 127).
The ASPI for Windows installed on this PC does not have expected function. Install newer version of ASPI for Windows.		
The ASPI for Windows installed on this PC does not support expected mode. Install newer version of ASPI for Windows.		
The ASPI manager installed on this PC does not support Windows. Install ASPI for Windows. [e.g. install wnaspi32.dll to your windows (system directory)].		

Care and Maintenance

Error message	Possible cause	Recovery
The Status Display does not appear when printing a document.	The Status Display function is not active	Follow the procedure below to make the setting active. <ol style="list-style-type: none"> 1. Click Start, select Settings, then click Printers. 2. Click the Panasonic KX-P8410 printer icon. 3. Click the File menu, then click Properties. 4. Click Details tab and Spool settings... 5. Click Enable bi-directional support for this printer, then click OK.
There was an error writing to LPT1: for the printer (Panasonic KX-P8410): There was a problem sending your document to the printer. Make sure the printer cable is connected and the printer is online. To continue printing, click retry. Windows will automatically retry after 5 seconds	Cable connection is improper or the printer is not ready.	Connect the printer (parallel cable) correctly or make the printer ready.
There was an error writing to KXP8410GDI: for the printer (Panasonic KX-P8410): The printer is not ready. Make sure it is turned on and online. To continue printing, click retry. Windows will automatically retry after 5 seconds	<ul style="list-style-type: none"> ● Cable connection is improper or the printer is not ready. ● The terminator setting is improper. 	Perform the following procedure. <ol style="list-style-type: none"> 1. Confirm that the terminator is correctly set. 2. Confirm that the printer is ready. 3. Confirm that the printer is correctly connected with a SCSI cable. 4. Turn off the computer, then turn it on again.
Unable to Allocate Memory!!	The memory for printing is insufficient.	<ul style="list-style-type: none"> ● Close all applications except for the one which controls the printer, then print it again. ● Turn off the computer, then turn it on again. Print the document again.

■ Some application settings may take priority over the printer driver settings.



Printer Driver For Windows NT 4.0

Error message	Possible cause	Recovery
ASPI Manager is not found. Install ASPI for Windows. (e.g. install wnaspi32.dll to your system32 directory).	SCSI Board and its driver are not installed correctly.	Correctly install SCSI board and its driver. (Refer to the instructions manual of the SCSI board.) Wnaspi32.dll will be installed or replaced with a new version.
Can not initialize ASPI for Windows. Install newer version of ASPI for Windows.	SCSI Board and its driver are not installed correctly.	Correctly install SCSI board and its driver. (Refer to the instructions manual of the SCSI board.) Wnaspi32.dll will be installed or replaced with a new version. For any other trouble related to SCSI , refer to the SCSI section of Care and Maintenance ( P. 127).
The ASPI for Windows installed on this PC does not have expected function. Install newer version of ASPI for Windows.		
The ASPI for Windows installed on this PC does not support expected mode. Install newer version of ASPI for Windows.		
The ASPI for Windows installed on this PC does not support Windows. Install ASPI for Windows. [e.g.install wnaspi32.dll to your system32 directory]		
Error writing to KXP8410GDI: for <print job name>: The printer command is invalid. Do you wish to retry or cancel the job?	Separator page has been set. When SCSI port is used, Separator page cannot be used.	Cancel the Separator page setting.
Error writing to LPT1: for "Application name": The device is not ready. Do you wish to retry or cancel the job?	Cable connection is improper or printer is not ready.	Connect the printer (parallel cable) correctly or make the printer ready.

Care and Maintenance

Error message	Possible cause	Recovery
<p>Error writing to "Port name" for "Application name": The request could not be performed because of an I/O device error. Do you wish to retry or cancel the job?</p>	<ul style="list-style-type: none"> ● Cable connection is improper or printer is not ready. ● The terminator setting is improper. 	<p>Perform the following procedure.</p> <ol style="list-style-type: none"> 1. Confirm that the terminator is correctly set. 2. Confirm that the printer is ready. 3. Confirm that the printer is correctly connected with a SCSI cable. 4. Turn off the computer, then turn it on again.
<p>System Process-Out of Virtual Memory</p> <p>Your system is running low on virtual memory. Please close some applications. You can then start the System option in the Control Panel and choose the Virtual Memory button to create an additional paging file or to increase the size of your current paging file.</p>	<p>Your system is running low on virtual memory.</p>	<p>Increase the virtual memory by following the procedure below.</p> <ol style="list-style-type: none"> 1. Click Start, Settings, then click Control Panel. 2. Double click the <i>System</i> icon. 3. Click the Performance tab. 4. Click Change.... 5. Increase the value of Initial Size [MB] and Maximum Size [MB]. 6. Click Set. 7. Click OK. 8. Click Close. 9. Click Yes in the System Settings Change dialog, then restart your computer. <p>If the same error message appears after increasing the virtual memory, increase it more.</p>

Status Display

Error message	Possible cause	Recovery
ASPI for Win 16 or 32 could not properly initialize itself. This may be caused by a lack of system resources.	Lack of system resources, or other trouble related to SCSI.	Close some application and retry. For any other trouble related to SCSI , refer to the SCSI section of Care and Maintenance ( P. 127).
Invalid LPT Port.	Unavailable LPT port is selected when using Windows 3.1.	Select the other available LPT port by following the procedure below. <ol style="list-style-type: none"> 1. Double click the Main icon. 2. Double click the Control Panel icon. 3. Double click the Printers icon. 4. Click Connect... . 5. Click the other port, then click OK. 6. Click Close.
Load Library Error! , File Open Error! or Install Error! appears and Status Display does not appear.	The necessary file is not installed in the computer.	Reinstall the KX-P8410 software.
No ASPI managers are loaded. This typically occurs when a DOS ASPI manager is not resident in memory.	SCSI board is not correctly set.	Correctly set the SCSI board in the computer. (Refer to the manual of the SCSI board.) For any other trouble related to SCSI , refer to the SCSI section of Care and Maintenance ( P. 127).
Not Detect.	<ul style="list-style-type: none"> ● The printer was turned on after turning on the computer. ● The terminator setting is improper. ● SCSI setting or cable connection is improper. 	Turn off the printer and the computer, then turn them on again. If the trouble still remains, confirm the following points. <ul style="list-style-type: none"> ● The terminator is correctly set. ● The SCSI board is correctly installed in the computer. ● The system is correctly connected with SCSI cables. ● Each SCSI device has a different ID Number.

Care and Maintenance

Error message	Possible cause	Recovery
One or more ASPI for DOS managers are loaded which do not support ASPI for Win16 or 32.	SCSI board is not set correctly.	Correctly set the SCSI board in the computer. (Refer to the manual of the SCSI board.) For any other trouble related to SCSI , refer to the SCSI section of Care and Maintenance (☞ P. 127).
There isn't available LPT Port.	Unavailable LPT port is selected when using Windows 3.1.	Select an available LPT port by following the procedure below. 1. Double click the Main icon. 2. Double click the Control Panel icon. 3. Double click the Printers icon. 4. Click Connect... . 5. Click the other port, then click OK . 6. Click Close .
This ASPI manager does not support this mode of Windows. You typically see this error code when running Windows in Real Mode	SCSI board is not set correctly.	Restart Windows in Enhanced mode.
SCSI device can not be used. Because ASPI dll file is not exist or doesn't match.	SCSI board is not installed correctly in the computer and/or it is not set correctly.	Confirm that the SCSI board is correctly installed in the computer and it is set correctly. (Refer to the manual of the SCSI board.) For any other trouble related to SCSI , refer to the SCSI section of Care and Maintenance (☞ P. 127).

Care and Maintenance

Error message	Possible cause	Recovery
SCSI device is not responded.	Printer is not responding.	Click Yes or No on the message window. Yes: Printer cannot be used. Turn off the printer and the computer, then turn them on again. No: Waits until the printer responds.
Status Display does not exist.	KX-P8410 software is not installed correctly.	Reinstall the KX-P8410 software.
winaspi.dll is not found.	SCSI board is not correctly set.	Correctly set the SCSI board in the computer. (Refer to the instructions manual of the SCSI board.) For any other trouble related to SCSI , refer to the SCSI section of Care and Maintenance (👉 P. 127).

Status Display Program

The Status Display program alerts the user to any errors. It displays an error message, identifies the problem area on the printer, and provides information regarding corrective action.

■For Windows 3.1 users:

When Windows 3.1 is started, the Panasonic Printer Status icon appears and stays on the screen. This enables you to display the printer's status at any stage during operation.

The Panasonic Printer Status dialog box appears when:

- A SCSI device error is found while using the printer driver.

This dialog box reduces to an icon when:

- The printer recovers from an error situation

If you have selected the "When device error" option in the Start Up box of the Setup for Status Display dialog box:

- The Panasonic Printer Status icon does not appear when Windows 3.1 is started
- The Panasonic Printer Status dialog box disappears after recovering from an error situation

Note:

- *The Setup for Status Display dialog box can be displayed by double clicking the Status display setup icon. In this dialog box you can display the Start Up box by clicking the Start Up tab.*

■For Windows 95 / Windows NT 4.0 users:

The Panasonic Printer Status dialog box appears when:

- A SCSI device error is found while using the printer driver

This dialog box disappears when:

- The printer recovers from an error situation

Printer Status Dialog Box

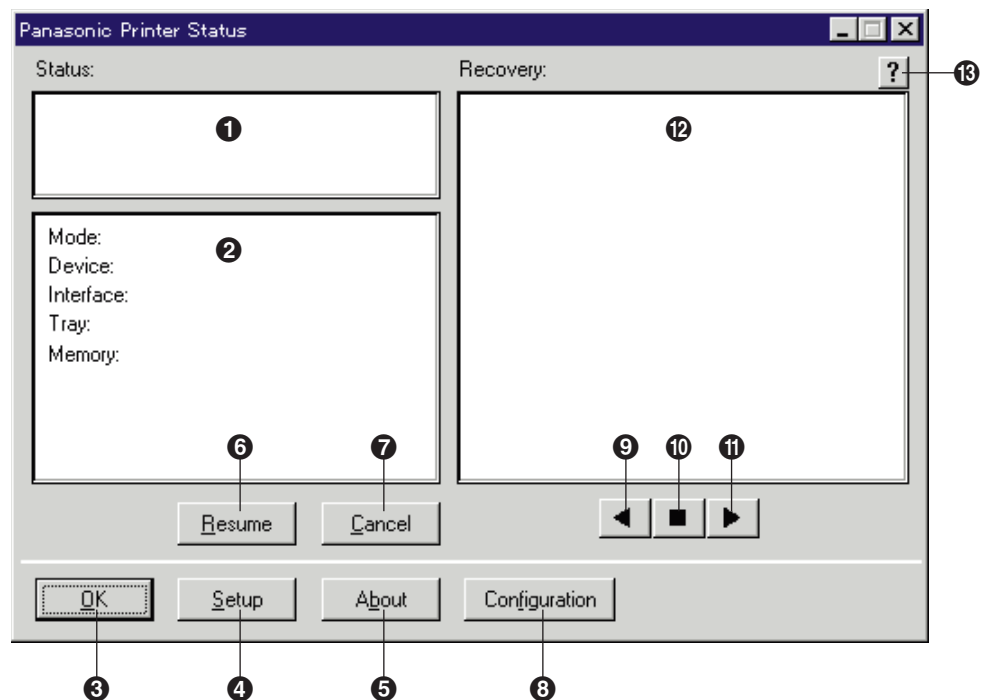

- ❶ This box shows an error or status message and the corresponding icon.
- ❷ This box lists the mode your printer is in, device name (printer), interface cable and tray being used, the built-in memory size of the printer and the name of the print job.
- ❸ This button minimizes the Panasonic Printer Status dialog box. Pressing the ESC key on the keyboard can also minimize it.
- ❹ This button displays the Setup for Status Display dialog box, where you can change different settings.
- ❺ This button displays the version of the Status Display.
- ❻ This button resumes printing after recovering from an error situation.
- ❼ This button cancels the print job which caused an error.
- ❽ This button displays the Panasonic Show Configuration dialog box.
- ❾ This button displays the previous recovery message.
- ❿ This button displays the initial recovery message.
- ⓫ This button displays the next recovery message.
- ⓬ This box displays a recovery procedure along with a picture.
- ⓭ This button provides you additional help.

Care and Maintenance

Repacking

It is highly recommended that you keep the original carton and ALL packing materials. Should you need to transport or ship your printer, please follow these instructions.

Safety Caution:

- *The printer weighs about 47.9 kg {105.5 lbs.}. It must be handled by two people.*

Notes:

- *Should you need to send your printer for service, consult your reseller first or Panasonic.*
- *Please use the original carton and all of the original packing materials.*
- *If you do not have the packing for the imaging unit and the transfer unit: contact Panasonic for packaging.*
- *Improper repacking of the printer may result in a service charge to remove spilled toner.*
- *Since the printer uses dry toner, extreme care must be taken when handling. The printer should be handled in the upright (vertical) position.*

Material required:

- Original cartons and packing materials
- Newspaper or drop cloth
- Shipping tape and scissors

Care and Maintenance

- 1** Turn off the printer; remove the power cord and all interface cables.
- 2** Remove the media tray(s) from the printer; remove the media from the tray(s).

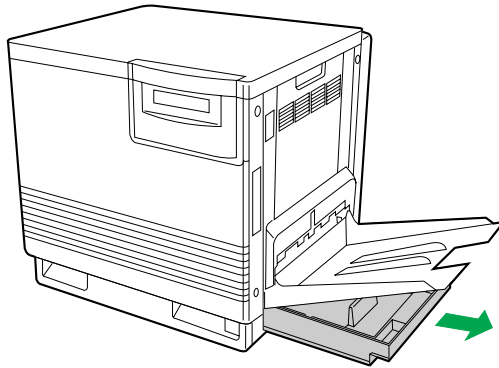

- 3** Press down on a media tray's metal plate. Place the cardboard packing material into the media tray.

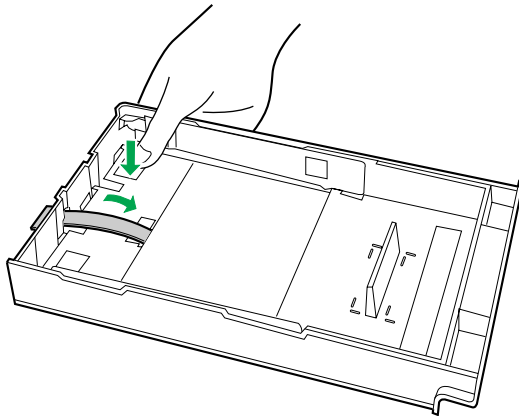

Care and Maintenance

4 Reinsert the media tray into the printer; use adhesive tape to secure the tray to the printer.

5 If you have other media trays, repack them for shipping or storage in their original shipping boxes.

- 6**
- 1** Open the printer's front door.
 - 2** Loosen the two thumbscrews by turning them counterclockwise.
 - 3** Turn the lower green lever 180° counterclockwise.

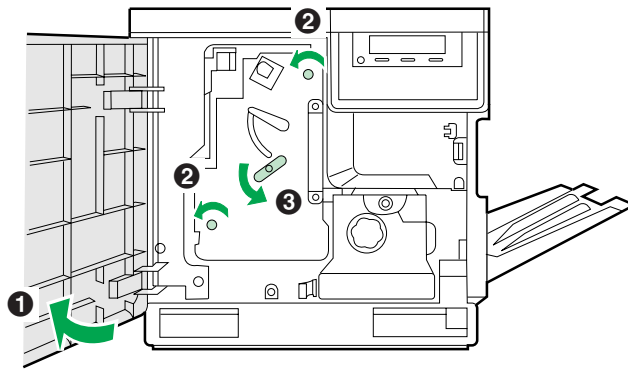

- 7**
- 1** Grasping the front green handle, slide the unit out until it catches.
 - 2** Lift up the green handle on the left. Pull the imaging unit out of the printer.

Important:

- Do not touch the green surface (the right side) or the black belt (the under side). Finger prints may affect the print quality.

Safety Caution:

- The imaging unit weighs approximately 6.5 kg {14.3 lbs.}. Always use the handles when lifting it.

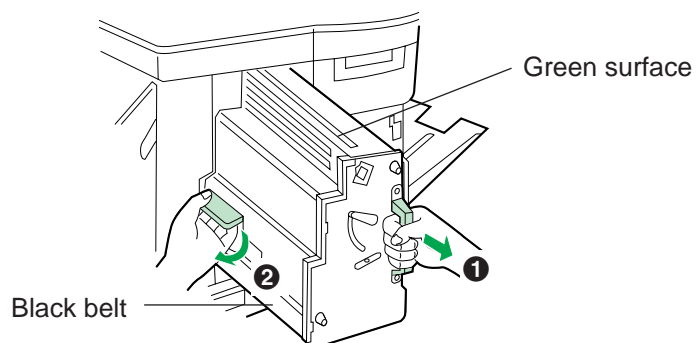

Care and Maintenance

- 8** Wrap the imaging unit with a protective black plastic sheet.

Caution:

- Do not expose the imaging unit to light for more than 45 seconds to avoid damage.

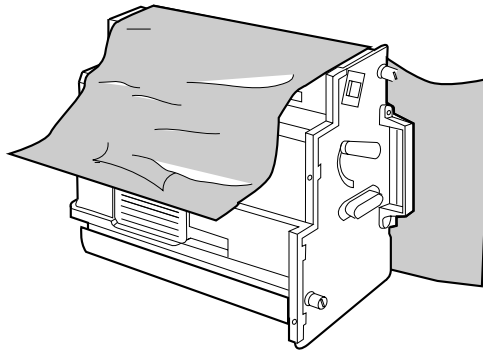

- 9** On the imaging unit, turn the upper lever 90° counterclockwise; this is necessary to protect the imaging unit during shipment.

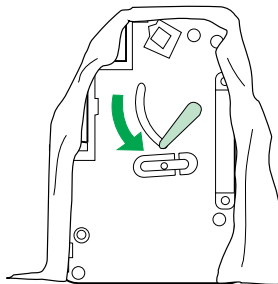

- 10** Insert the imaging unit into the packaging.

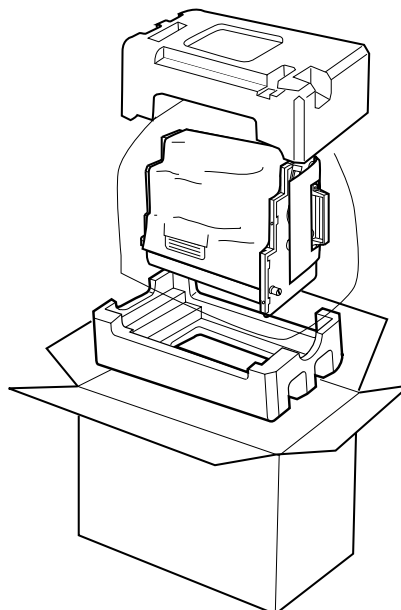

Care and Maintenance

- 11** ❶ Open the left side door.
❷ Using the green handles, slide the paper feeder out.

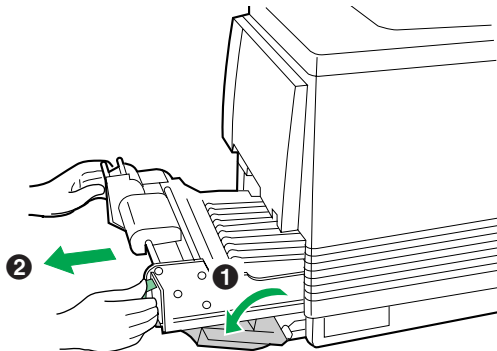

- 12** ❶ Push in on green tabs to unlock the cover.
❷ Raise the cover until it catches in the open position.

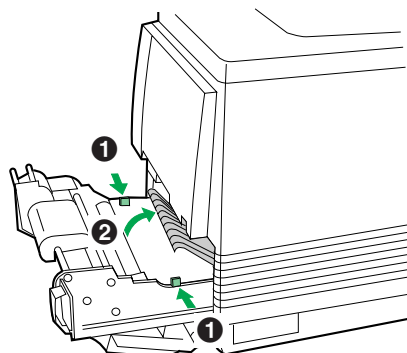

- 13** ❶ Rotate the transfer unit's green handles up.
❷ Lift out the transfer unit.

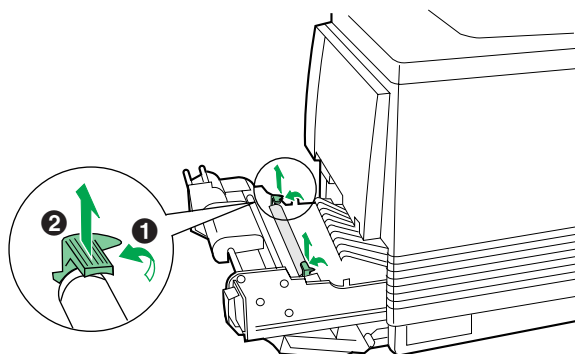

- 14** Place the transfer unit on newspaper or drop cloth. Rotate the handles down and wrap the transfer unit with a piece of paper and adhesive tape.

Note:

- Do not touch or bump the roller: it can damage the roller

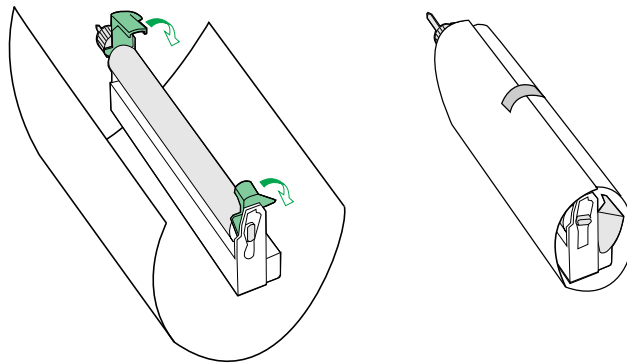

- 15** Install the plastic cover and insert the transfer unit into a plastic bag and seal the end tightly. Install the transfer unit into the packaging.

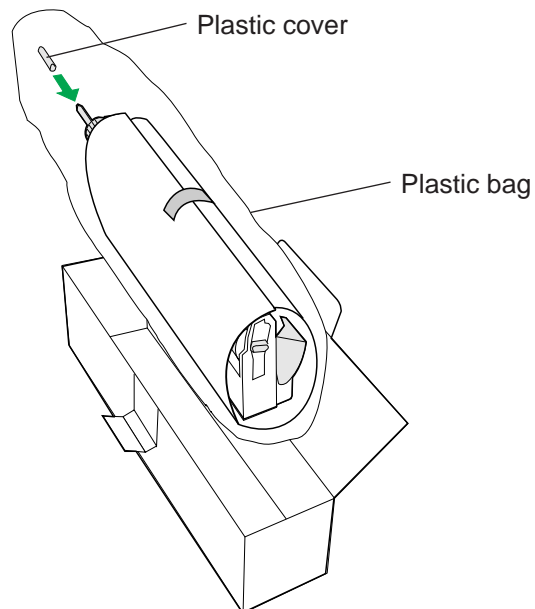

Care and Maintenance

16 Packing the toner cartridges:

- 1 Open the right side door.
- 2 Remove a toner cartridge.

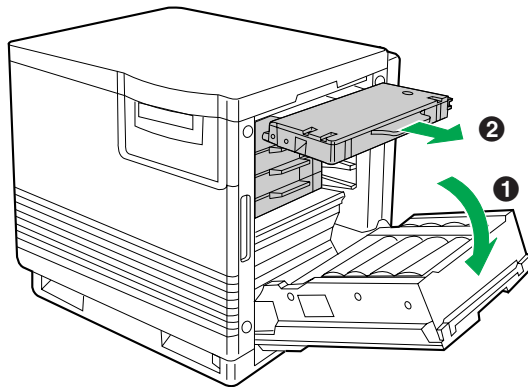

Caution:

- To avoid possible toner spillage, do not tilt the cartridge.

- 3 Replace the shipping cover.
- 4 Secure the shipping cover with adhesive tape.

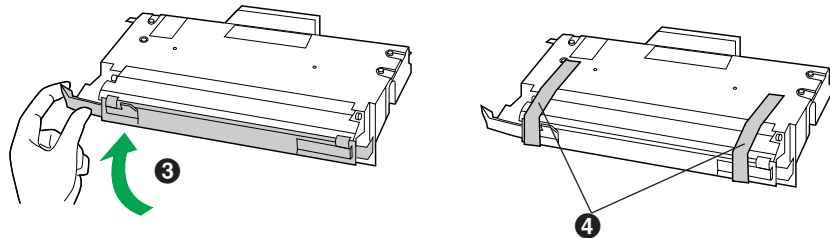

- 5 Insert each toner cartridge into a plastic bag and seal the end of the bag tightly.

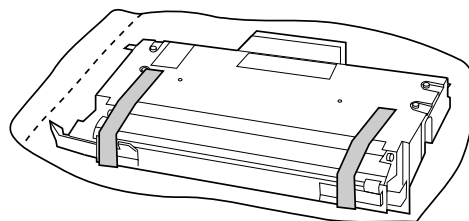

- 6 Repeat instructions 2 to 5 for each toner cartridge.

17 Wipe off any loose toner in and around the printer.

Note:

- If a toner vacuum is available, it is the best tool for cleaning spilled toner. Do not use a standard office vacuum; the toner will not be retained by typical vacuum dust collectors.

- ## 18
- 1 Raise the output tray and secure it to the printer with adhesive tape.
 - 2 Secure the front door, the multi-purpose tray and the left side door to the printer with adhesive tape.

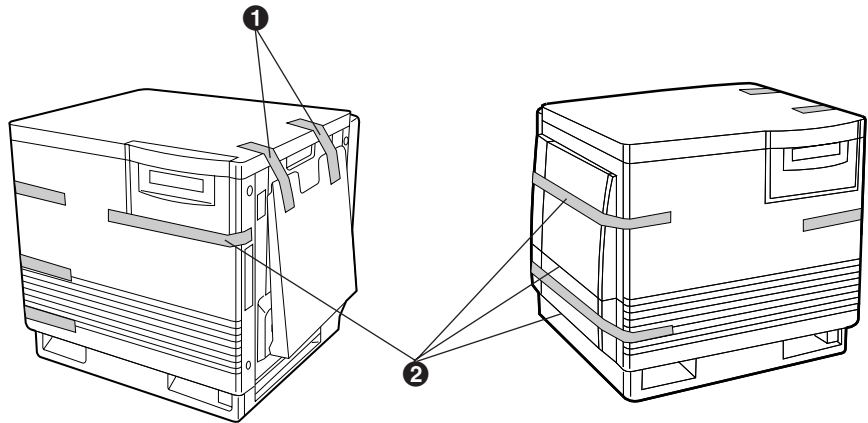

If you don't have a 2nd Cassette Feeder, go to step 20.

19 If you have a 2nd Cassette Feeder:

- 1 Lift the printer up and away from the 2nd Cassette Feeder.

Safety Caution:

- The printer weighs approximately 41.4 kg {91.2 lbs.} and the 2nd Cassette Feeder weighs approximately 14.3 kg {31.5 lbs.}. Observe standard precautions for lifting heavy objects.

- 2 Repack the 2nd Cassette Feeder in its original shipping box.

Care and Maintenance

- 20** Repack any other accessories in the original shipping box.
- 21** Repack the printer in the original shipping box. Make sure that you keep the printer upright and level when moving.

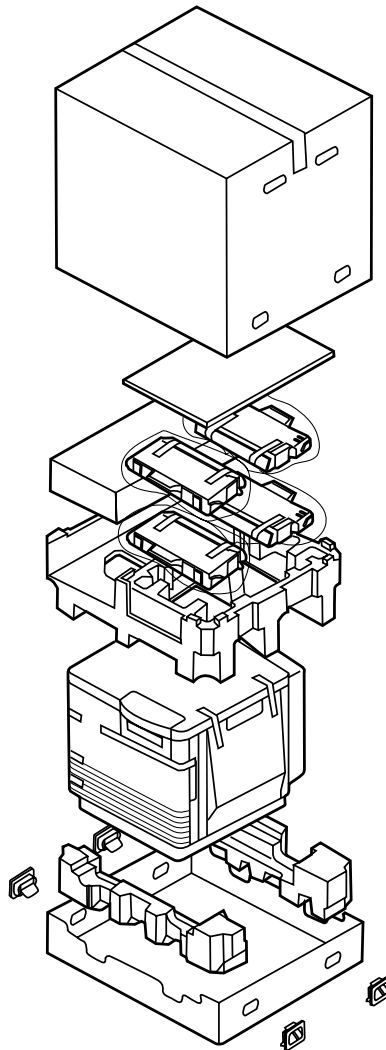

Appendix

Specifications

Printer

Power source

Refer to the nameplate on the rear of the unit.

Temperature

Operating: 10°C to 32.5°C (50°F to 90.5°F)

Best Print Quality: 15°C to 25°C (59°F to 77°F)

Storage: 0°C to 40°C (32°F to 104°F)

Humidity

Operating: 20% to 80% RH

Best Print Quality: 30% to 70% RH

Storage: 10% to 80% RH

Warm-up time

Less than 300 seconds

Power consumption

850 W Max. (printing with fuser on)

35 W (standby with fuser off)

25 W (Energy Star mode)

Meets Energy Star power conservation requirements.

Mass {Weight} of standard unit with all consumables

(without optional 2nd Cassette Feeder)

47.9 kg {105.5 lbs.}

Dimensions of standard unit (Without 2nd Cassette Feeder)

Height: 463 mm (18.2")

Depth: 493 mm (19.4")

Width: 510 mm (20.1") [784 mm (30.9") with the output tray]

Noise level

53 dB(A) [Printing mode]

47 dB(A) [Standby mode]

Printing method

Semiconductor Laser

Paper output

Up to 500 sheets [75 g/m² (20 lbs.)]

Resolution

600 x 600 dpi

1200 x 1200 dpi (additional RAM required)

Appendix

Maximum printing speed

The print speeds listed in the following table represent the time the printer produces multiple prints on various media and resolution (**Continuous throughput rate**).

Continuous Print Speed (ppm)

	Plain Paper		Legal		Transparency	
	color	mono	color	mono	color	mono
600 x 600 dpi	3.5	14	1.75	7	1.75	7
1200 x 1200 dpi	1.75	7	0.87	3.5		

RAM buffer

Standard 8 MB (expandable to a maximum of 72 MB with optional SIMMs)

Printing:

Total Memory	Selectable Print Quality Mode	Printable without Memory Overflow
8 MB (Standard)	Fast (300 dpi)	Letter, A4 *1
	Standard (600 dpi)	Letter, A4 *1
16 MB (Add 8 MB)	Fast (300 dpi)	Letter, A4, Legal
	Standard (600 dpi)	Letter, A4 *1
56 MB (Add 48 MB)	High Quality (1200 dpi)	Letter, A4 *1
72 MB (Add 64 MB)		Letter, A4 Legal

*1 Documents can be printed on Legal size paper when the print style is set to Color Graphics (☞ P. 69, 79) provided the data size of the document is small.

Note:

- More than 32 MB is required on the printer to use "Printer memory usage" in the printer driver (☞ P. 73, 91).

Interface

Standard: Bidirectional Parallel, SCSI-2
 Option: 10 baseT, 10 base2

Altitude

Operating: 0 to 2,500 m (8,000 ft.)
 Storage: 0 to 4,000 m (13,125 ft.)

Media

Media Sizes

Medium	Size	Dimensions
Paper	Letter	216 mm x 279 mm (8.5" x 11")
	A4	210 mm x 297 mm (8.3" x 11.7")
	Legal	216 mm x 356 mm (8.5" x 14")
Transparency	Letter	216 mm x 279 mm (8.5" x 11")
	A4	210 mm x 297 mm (8.3" x 11.7")
Envelope	#10	104.9 mm x 241.3 mm (4.13" x 9.5")

Note:

- Please store your paper according to the recommendations of the manufacturer.

Margins and Print Area

When the image is printed on the media, the image (print area) is a bit smaller than the media size. You may need to adjust the page margins in the application software to match the print area.

The following table and illustrations show the page sizes, the largest print areas, and the margins for the media sizes supported on this printer.

Media	Page size	Print area	Margins		
			Top	Bottom	Sides
Letter	216 mm x 279 mm (8.5" x 11")	208 mm x 269 mm (8.2" x 10.6")	5.6 mm (0.22")	5.6 mm (0.22")	3.6 mm (0.14")
A4	210 mm x 297 mm (8.3" x 11.7")	200 mm x 287 mm (7.9" x 11.3")	5.1 mm (0.2")	4.7 mm (0.19")	4.7 mm (0.19")
Legal	216 mm x 356 mm (8.5" x 14")	208 mm x 343 mm (8.2" x 13.5")	5.8 mm (0.23")	5.8 mm (0.23")	3.6 mm (0.14")

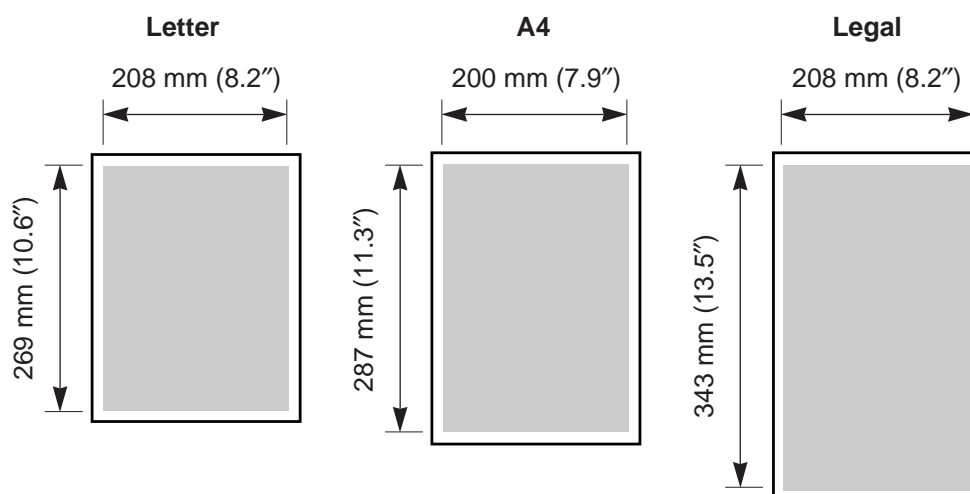

■ Paper Weight

The printer is designed to work well with most types of paper. However, differences in paper may have significant effects on the quality of the print or the reliability of paper handling.

It is strongly recommended that you always test paper before purchasing it to make sure it provides desirable performance.

Media tray *	One-sided printing	B&W	60 to 105 g/m ² (16 to 28 lbs.)
		Color	75 to 105 g/m ² (20 to 28 lbs.)
Multi-purpose tray	One-sided printing	B&W	75 to 165 g/m ² (20 to 44 lbs.)
		Color	75 to 165 g/m ² (20 to 44 lbs.)
	Two-sided printing	B&W	75 to 105 g/m ² (20 to 28 lbs.)
		Color	90 to 105 g/m ² (24 to 28 lbs.)

- Recommended paper (for optimum performance):

LETTER/LEGAL : Hammermill LASERPRINT 90 g/m² (24 lbs.)
 A4 : NEUSIEDLER COLOR COPY 90 g/m²

* We do not recommend the use of 105 g/m² (28 lbs.) paper in areas of high or low humidity and temperature since paper feed problems may be experienced.

■ Types of Paper to Avoid

- Extremely smooth or shiny paper or paper that is highly textured
- Letterhead imprinted with low temperature or thermography. These materials may transfer onto the fusing roller and cause damage. Any pre-printed paper should use inks compatible with 200°C (392°F) for 0.1 second.
- Damaged or wrinkled paper, or paper with irregularities such as tabs, staples, etc.
- Multipart forms or carbonless paper
- Paper with a 25% or more cotton and/or fiber content
- Ink jet paper (It may transfer onto the fuser roller and cause damage.)

■ Two-Sided Printing

Two-sided printing is possible by using the multi-purpose tray. However, you should not expect the same print quality and reliability that you get with one-sided printing. We strongly recommend that you follow the guidelines below.

- Do not load more than 10 sheets in the multi-purpose tray.
- Before loading paper in the multi-purpose tray, adjust it so that the edges are even.

■ Transparencies and Labels

You may also print on transparencies and labels that are made for the printer. Panasonic has tested and found that the following work satisfactorily.

OHP transparency	3M CG3700
Labels	AVERY 5163, AVERY 5164, AVERY 5165 Avery L7163, Avery L7165, Avery L7166, Avery L7167 Avery L7168, Avery L7169

- *Re-using transparencies that have been fed through the printer once (for example, after jams or if the transparency is ejected without being printed) can reduce the life of the consumables and paper path components.*
- *When using transparencies, if the print quality is poor, print on the other side.*
- *With any label stock, the labels must completely cover the backing material.*

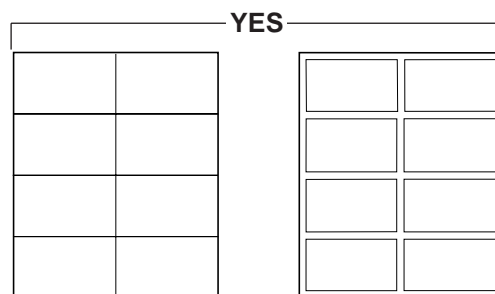

Labels cover the entire backing material.

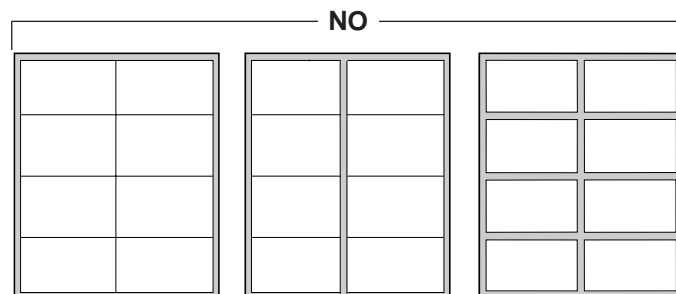

The backing material is exposed.

■ Envelopes

It is recommended that you print in black text only and purchase high quality #10 laser envelopes with diagonal seams, as shown in the diagram below:

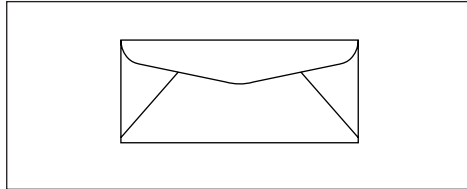

High quality envelopes have the following characteristics:

- A thin, sharply creased leading edge
- Paper weight of 90 g/m² (24 lbs.)
- Flat, free of curls, wrinkles, nicks, etc.

It is not recommended that you use envelopes with any of the following characteristics (using these may result in paper jams):

- Irregularly shaped envelopes
- Envelopes with curls, wrinkles, nicks, twists, dog-ears or other damage
- Envelopes with side seam construction
- Highly textured envelopes, or with extremely shiny surfaces
- Envelopes that seal by removing a peel-off strip
- Envelopes with more than one flap to be sealed
- Self-adhesive envelopes
- Envelopes that are baggy or not sharply creased
- Embossed envelopes
- Envelopes that have previously been printed on

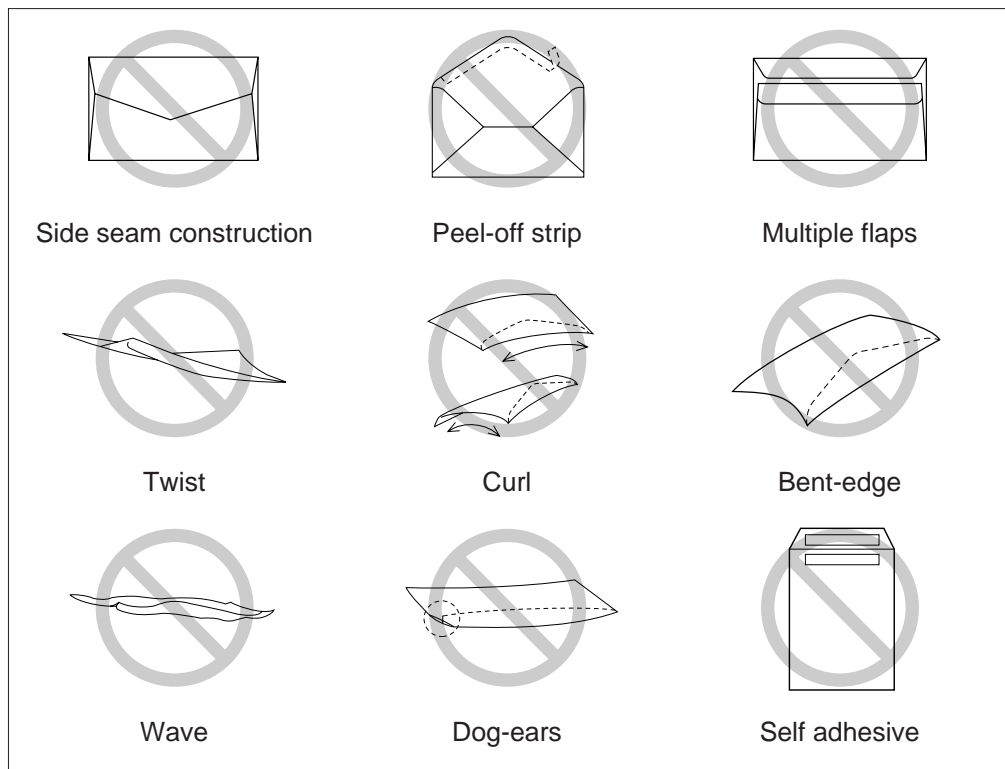

Do not attempt to print on any of the following types of envelopes. These may cause damage to your printer.

- Envelopes with clasps, snaps or tie strings (see Figure 1)
- Envelopes with transparent windows (see Figure 2)
- Envelopes that will melt, discolor, scorch offset or release hazardous emissions when exposed to 200°C (392°F) for 0.1 second
- Envelopes that use encapsulated types of adhesive that do not require moistening but rely on pressure to seal them

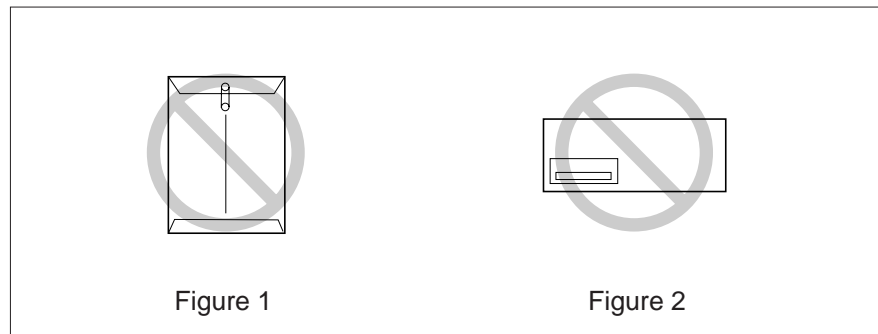

Always test a sample of the envelopes you are thinking of buying. Confirm that the envelope performs acceptably.

For best printing results

- Avoid printing in high humidity i.e., above 70%.
High humidity may cause the envelope to curl and pick up excess toner.
High humidity may also cause the envelope to seal.
- Avoid printing below 10°C (50°F) with less than 30% relative humidity.
Low temperature with low humidity may cause light printing.

Envelope storage is very important. Store them away from moisture and humid air, where they can lay flat and their edges won't be bent or damaged. The humidity should not exceed 70% RH.

Software

Windows Version

- **Windows 95, Windows 3.1, Windows NT 4.0 (Intel Only)**

GDI Printer Driver

Color Management: ICM

Bundled Software

- Panasonic font manager with 96 fonts

System Requirement

CPU:	More than Pentium or Pentium PRO (133 MHz or faster CPU is recommended.)
Operating System:	Windows 3.1, Windows 95 or Windows NT 4.0 (Intel Only)
Memory:	16 MB or more (More than 32 MB is recommended.)
Free disk space	100 MB or more
Virtual memory:	16 MB or more (More than 32 MB is recommended.) for Windows 3.1 / 95 50 MB or more (More than 100 MB is recommended.) for Windows NT 4.0.
Display:	Video card that display more than 256 colors. (A video card that can display more than 32,000 colors is recommended.)
Drive:	CD-ROM drive

Bidirectional Parallel Interface

The bidirectional parallel interface is based on the IEEE P1284-C standard.

If your computer has a bidirectional parallel port, the printer driver and printer can take advantage of faster data transfer.

Specifications

Connector Type	IEEE 1284-C type connector
Cable	Use a shielded cable 2 m (6.6 ft.) or less in length.

Pin configuration

Signal Pin	Return side pin	Signal
1	19	Busy
2	20	Select
3	21	nAck
4	22	nFault
5	23	PError
6	24	Data 1
7	25	Data 2
8	26	Data 3
9	27	Data 4
10	28	Data 5
11	29	Data 6
12	30	Data 7

Signal Pin	Return side pin	Signal
13	31	Data 8
14	32	nInit
15	33	nStrobe
16	34	nSelectin
17	35	nAutoFd
18	—	+5V(Host)
36	—	+5V(Peripheral)

Parallel Interface connector (printer side)

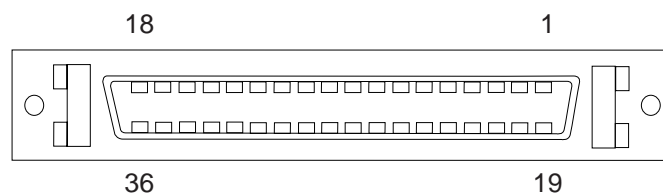

Notes:

- "Return" denotes the return side wire of a twisted pair cable and is connected to signal ground.
- Be sure to use only a shielded cable. The printer will not operate properly if any of the pins is not connected.

Appendix

SCSI Interface

The Panasonic SCSI interface is based on fast SCSI-2 ANSI standard.

Specifications

Connector Type	50-Pin Half Pitch Pin-type Connector
Cable	Use a shielded cable for SCSI-2 (FAST SCSI). The total length of the SCSI chain must not exceed 3 m (9.8 ft.) to ensure reliable operation.

Pin Configuration

Signal Pin	Signal	Signal Pin	Signal
1	GND	26	-DB(0)
2	GND	27	-DB(1)
3	GND	28	-DB(2)
4	GND	29	-DB(3)
5	GND	30	-DB(4)
6	GND	31	-DB(5)
7	GND	32	-DB(6)
8	GND	33	-DB(7)
9	GND	34	-DB(P)
10	GND	35	GND
11	GND	36	GND
12	(RESERVED)	37	(RESERVED)
13	(OPEN)	38	TERMPWR
14	(RESERVED)	39	(RESERVED)
15	GND	40	GND
16	GND	41	-ATN
17	GND	42	GND
18	GND	43	-BSY
19	GND	44	-ACK
20	GND	45	-RST
21	GND	46	-MSG
22	GND	47	-SEL
23	GND	48	-C/D
24	GND	49	-REQ
25	GND	50	-I/O

SCSI Interface Connector (Printer side)

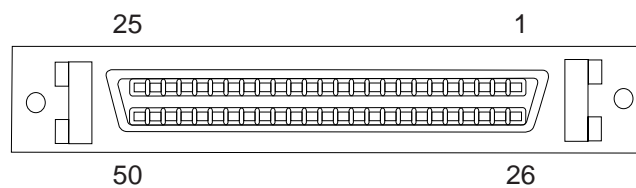

Index

A

About button71, 73, 95
AC inlet18, 34
Add Port button84
Advanced tab78
Alternate Drivers88
Auto Continue59, 60
Auto, tray selection68, 77

B

Bidirectional Parallel Interface161
Black Text, print style69, 79
Blue, Color Balance96
Brightness94

C

Calibration Offset59, 60
Calibration Page54-56, 58
Calibration Test Print59, 60, 62
◀/CANCEL button19, 59, 61
Cautions8, 10, 12
Caution labels10
CD-ROM13, 17, 42, 43
Checked port84
Cleaning the printer99
Cleaning the sensor100
Clearing a jam105
Client computer48
Color adjustment94
Color balance96
Color Calibration59, 60
Color calibration card17, 56
Color calibration page56
Color Graphics, print style69, 79
Color Graphics type70, 80
Color management71
Color Photo, print style69, 79
Configuration Page59, 62
Connecting
 Printer to computer33
Contents6, 7
▲/CONTINUE button19, 59, 62
Contrast94
Copies68
Copy Count77
CYAN/MAGENTA/YELLOW/BLACK59, 60

D

Data Timeout59, 60
Details tab64, 66
Device Settings tab91
Dither70, 80
Document Options79

E

End-user license agreement4
Energy Star3, 59, 60
ENTER button19, 59, 62
Envelopes158
ERROR indicator20
Error messages130
 Printer LCD panel130
Even pages98

F

Face down, output order67, 81
Face up, output order67, 81
Fast, print quality71, 80, 154
Features14
Font manager52, 160
For users in U.K.11
For your safety8
Form To Tray Assignment92
Front door18, 21, 109, 112
Fuser18, 60, 104, 109, 114

G

Graphics/Color tab,69
Gray Scale, print style69, 79
Green, Color Balance96

H

High quality, print quality71, 80, 154
Hue94
Hyper-Tetra Adjustment71, 93-96
 Color Adjustment94
 Color Balance96

I

Image Color Matching (ICM)71
Imaging unit18, 21, 61, 101, 102
Installing an alternate driver89
Installing the KX-PS8410 software40
Installing the printer driver40-50
Installing the SCSI port85
Installing the toner cartridges23
Interface15
 Bidirectional Parallel Interface161
 Cable13, 34, 35, 161, 162
 Connector34, 35
 SCSI35, 162

Index

J

Jam at A	105, 106
Jam at B	105, 108
Jam at C	105, 109
Jam at D	105, 113
Jam at E	105, 115
Jam at MPT (multi-purpose tray)	105, 116
Jam clearing	105

L

Labels	157
LCD panel	19
Left side door	18, 29, 106
Limit mark	27, 31
Loading envelope	32
Loading labels	32
Loading media in the multi-purpose tray	29
Loading paper	30
Loading paper/transparencies in the media tray	25
Lower, tray selection	68, 77

M

Maintenance	60, 61
Margins and print area	28
Media problems	125
Media sizes	155
Media specifications	155
Media tray	18, 25, 106
Media type	68
Memory	72, 73
MENU/EXIT button	19, 59, 62
Menu Mode	59
Metafile Spooling	81
Microsoft Word 95	97
Middle, tray selection	68, 77
Minimum space requirements	16
Mirror image	71, 81
Moving the unit	9
MPT (multi-purpose tray), tray selection	68, 77
Multi-purpose tray	18, 29, 30, 116

N

Network	47, 59, 61
Network environment	47

O

Odd pages	97
Oil supply roll	61, 104, 110, 114
Option tab	72
Orientation	67, 77
Output order	67, 81
Output tray	18, 22, 115

P

Page Setup tab	76
Panasonic Font Manager	52
Paper	
Feeder	99, 100, 108
Loading	30
size	67, 76
source	68, 77
trays	25
Paper 2nd side, media type	68, 77
Paper-pick	99, 100
Paper/Output	78
Paper tab	67
Parallel interface	161
Parallel interface cable	34
Parallel interface connector	34
Part names	18
Front side view	18
Printer panel overview	19
Rear side view	18
PC	15
Plain paper, media type	68, 77
Plug and Play	43
Portrait, orientation	67, 77
Ports tab	84
Power cord	34
Power ON	38
Power source	16
Power switch	18
Preparing the imaging unit	21
Presentation, print style	69, 79
Preview button	95
Print as a mirror image	71, 81
Printer driver for Windows 3.1	40, 41
Printer driver for Windows 95	40, 42
Printer driver for Windows NT 4.0	40, 45
Printer LCD panel	130
Printer memory	72, 91
Printer memory usage	73, 92
Printer panel	18, 19
Printer Status dialog box	143
Printing a test page	39

Print quality	.71, 80, 154
Fast	.71, 80, 154
High quality	.71, 80, 154
Standard	.71, 80, 154
Print quality problems	.126
Print style	.69, 79
Print to the following port	.66

Q

Quality	.71, 80, 154
---------	--------------

R

READY indicator	.20
Red, Color Balance	.96
Removing the KX-P8410 software	.51
Removing the printer driver	.50
Repacking	.144
Reset button	.95
Reset Calibration	.59, 60
Resolution	.70, 80
Restore Defaults button	.73
Right side door	.18, 23, 114

S

Saturation	.94
SCSI-2 board	.15, 35
SCSI cable	.35
SCSI connector	.18, 35
SCSI ID NO. switch	.18, 35, 37
SCSI interface specifications	.162
Server computer	.47
Setting media thickness	.29
Setting the color density	.54
Setting the SCSI ID Number	.37
Setting the Terminator	.37
Setting up the output tray	.22
Shared	.88
Sharing tab	.88
Sharing the printer	.89
Software specifications	.160
Specifications	.153
Interface	.161, 162
Media	.155
Software	.160
Static electricity damage	.13
Status display	.139
Status Display program	.142
Supplies	.61

System	
Requirements	.15
Setting	.59, 60

T

Technical support calls (U.S.A.)	.5
Terminator switch	.18, 36, 37
Test Page	.39
Thickness	
Media	.29
Switch	.29
Toner cartridges	.103
Trademarks	.2
Transfer unit	.61, 104
Transparencies and labels	.157
Transparency	.25, 157
Transparency, media type	.68, 77
Tray selection	.68, 77
Troubleshooting	.117
Two-sided printing	.156
Types of paper to avoid	.156

U

Unpacking	.17
Upper green lever	.21
Use image color matching (ICM)	.71
User replaceable components	.103
Using Hyper-Tetra Adjustment	.71, 81, 93
Using the printer in a network environment	.47

W

Warnings	.8
Windows 3.1	.15, 40, 41, 51, 52, 64, 93, 127, 133, 142
Windows 95	.15, 40, 42, 51, 53, 63, 93, 128, 135, 142
Windows NT 4.0	.15, 40, 45, 51, 53, 74, 83, 93, 129, 137, 142